



FIRE-LITE® Alarms

www.firelite.com

December 8, 2004

DF-52381 • C-90

**ACC•25/50
AUDIO•COMMAND•CENTER•25/50
Voice Evacuation Control Panel**

Section: Emergency Voice Evacuation

GENERAL

The Fire•Lite AUDIO•COMMAND•CENTER•25/50 (ACC•25/50) is a state-of-the-art, single- or dual-circuit (25 watts each) Emergency Voice Evacuation Control Panel (EVAC). The ACC•25/50 provides the ability to record five field-programmable messages (up to 60 seconds total message duration) with an integral commercial-grade emergency communications microphone or from an external audio source. Significant technological enhancements set the ACC•25/50 apart from other EVAC panels — these include full supervision in both active (alarm or music) and standby conditions, supervision of amplifier outputs, field wiring, message generator, all tone generators, and the microphone. The integral power supply is capable of charging up to 18 AH batteries, which can be housed in the ACC•25/50 cabinet.

The ACC•25/50 is suitable for use as an adjunct (slave or stand-alone) to most UL-Listed Fire Alarm Control Panels (FACPs). An optional 25 watt, 25 V_{RMS} audio amplifier is available for system expansion to 50 watts (providing dual 25-watt speaker circuits) or as a secondary amplifier in jurisdictions requiring such backup. A 70.7 V_{RMS} converter is also available for independently converting amplifiers to meet retrofit needs.

A host of field-programming options, including the capability of five custom messages (fire, tornado, evacuation, hazmat, non-fire, multi-language, etc.) make the ACC•25/50 the most versatile voice evacuation system available.

Some Suitable Applications:

- ✓ Schools ✓ Auditoriums ✓ Dormitories ✓ Theatres
- ✓ Restaurants ✓ Places of Worship ✓ Lodging
- ✓ Office Buildings ✓ Factories

STANDARD FEATURES

- Integral 25 watt, 25 V_{RMS} audio amplifier with single Style Z (Class A) or Style Y (Class B) speaker circuit (expandable to 50 watts using the ACC-AAM25).
- Modular design for maximum system flexibility and ease of service.
- Five Command Input Circuits (CMD) are available for activation by an FACP.
- Two command input circuits can be independently field-programmed for activation by a Notification Appliance Circuit (NAC) or contact closure.
- Three command input circuits activate on contact closure.
- Manual deactivation of speaker zones.



MEA
341-03-E
(ACC-25/50,
ACC-AAM25)



California
State Fire
Marshal
6911-0075:207



52381acc.jpg

- **Command inputs allow:**
 - One 60-second message.
 - Two 30-second messages.
 - Three 20-second messages.
 - Four 15-second messages.
 - Five 12-second messages.
- Microphone time-out feature.
- Nineteen different system and diagnostic LEDs.
- Two Form-C trouble relays (System & AC Power Loss).
- *Optional equipment:* second amplifier; local playback speaker; and remote microphone.
- Integral digital message generator with standard, factory-prerecorded emergency evacuation message.

Fire•Lite® Alarms is a Honeywell company.

This document is not intended to be used for installation purposes. We try to keep our product information up-to-date and accurate. We cannot cover all specific applications or anticipate all requirements. All specifications are subject to change without notice.

For more information, contact Fire•Lite Alarms, One Fire-Lite Place, Northford, Connecticut 06472. Phone: (800) 627-3473, Toll-Free FAX: (877) 699-4105.

**ISO 9001
CERTIFIED**
ENGINEERING & MANUFACTURING
QUALITY SYSTEMS



Made in the U.S.A.

- Custom messages are field recordable, without the addition of costly add-on modules, utilizing the integral microphone or the audio input jack.
- Digital message may be field-selected for 3, 4, 6, 8, or infinite repeat.
- Built-in alert tone generators with steady, slow whoop, high/low, or chime tone capability.
- Field-selectable lead-in/trailing tone selection.
- Alert tone selection may be field-programmed to conform with ANSI S3.41 Audible Emergency Evacuation Signal (Temporal Pattern), per NFPA.
- Speaker zone control via CMD inputs or keypad.
- Dual-optically-isolated, trigger input circuits are independently field-programmable for activation by polarity reversal (host FACP NAC) or dry-contact closure.
- Zone 1 switch-programmable for All-Call operation.
- Integral diagnostic LEDs include: Power, System Trouble, Microphone Trouble, Message Generator Trouble, Tone Generator Trouble, Amplifier Fault, and others.
- Independent Form-C trouble relay allows FACP to monitor voice system while in active (alarm) state.
- Integral piezo provides local audible indication for troubles.
- Fully supervised in *Standby* and *Active* states, including integral microphone, amplifier output, message generator, speaker wiring, and tone generators.
- Independent amplifier supervision: current limit, audio level, short circuit protection.
- All outputs are power-limited.
- Auxiliary power output provides local power for addressable control modules when used to activate the ACC•25/50.
- Compatible with ALL Fire•Lite FACPs, as well as other manufacturers' panels.
- Background music capability (requires AHJ approval).
- When employing the background music option, total output power per amplifier is reduced to 20 watts.

OPTIONAL MODULES

ACC-AAM25

- 25 watt, 25 V_{RMS} audio amplifier module.
- Field-programmable for system expansion to 50 watts (providing dual 25-watt speaker circuits) or as a backup to the primary 25 watt amplifier where required.
- Provides single Class A or Class B speaker circuit.
- Utilizes plug-in-style terminal blocks for ease of service and maintenance.
- Fully supervised and power-limited.
- Diagnostic LEDs include: yellow "trouble" LED (cable fault, 70 V_{RMS} fault, amp fault) and green "amp functional" LED.

FC-XRM70

- Converts 25 V_{RMS} audio outputs to 70.7 V_{RMS} for retrofit applications.
- Plugs directly on ACC-AAM25 module(s), allowing independent conversion to 70.7 V_{RMS}.

FC-LPS

- Provides local digital message playback for user review of field-recorded custom messages.

STANDARDS AND CODES

The ACC•25/50 complies with the following standards: **NFPA 72** National Fire Alarm Code; **NFPA 101** Life Safety Code; **UL 864** Standard for Control Units for Fire Alarm Systems.

SPECIFICATIONS

Command input circuits (CMD1 and CMD2):

- Trigger input voltage: 10.5 – 29 VDC.

NOTE: When programmed for reverse-polarity activation.

Trouble contact rating:

- 2.0 A at 30 VDC (resistive), 0.6 A @ 125 VAC (resistive).

Auxiliary power output:

- Specific application power: 24 V, 35 mA.

Primary (AC) power:

- 1.6 A maximum @ 120 VAC, 50/60 Hz.

Secondary power (battery) charging circuit:

- Supports lead-acid batteries only.
- Float-charge voltage: 27.6 V.
- Maximum charge current: 800 mA.
- Maximum battery charging capacity: 18 AH.

CABINET SPECIFICATIONS

Door: 26.174" (66.482 cm) high x 15.780" (40.081 cm) wide x 1.125" (2.858 cm) deep. **Backbox:** 26.0" (66.040 cm) high x 15.5" (39.370 cm) wide x 4.75" (12.065 cm) deep, depth includes door.

CONTROLS AND INDICATORS

LED INDICATORS

1. Power On (*green*).
2. System Trouble (*yellow*).
3. Message Generator Trouble (*yellow*).
4. Tone Generator Trouble (*yellow*).
5. Microphone Trouble (*yellow*).
6. Record/Playback (*green*).
7. Zone 1 (*green* = Active, *yellow* = Manual Deactivation).
8. Zone 2 (*green* = Active, *yellow* = Manual Deactivation).

Other system LEDs: Battery Trouble, Charger Trouble, Ground Fault, Speaker Circuit Trouble, and Amplifier Supervisory.

ORDERING INFORMATION

ACC-25/50: 25 watt, 25 V_{RMS}, emergency Voice Evacuation Control Panel (VECP) with integral commercial microphone, digital message generator, and single-/dual-channel Class A or Class B speaker circuits.

ACC-AAM25: optional 25 watt, 25 V_{RMS} Audio Amplifier Module with single Class A or Class B speaker circuit.

FC-XRM70: optional 70.7 V_{RMS} Converter Module (*one required per amplifier, consult factory for availability*).

FC-RM: optional Remote Microphone, includes backbox (*only one FC-RM per system*).

FC-LPS: optional Local Playback Speaker.

BAT-1270: battery, 12 volt, 7.0 AH (*two required*).

BAT-12120: battery, 12 volt, 12.0 AH (*two required*).

BAT-12170: battery, 12 volt, 18.0 AH (*two required*).

APPLICATION EXAMPLES

The AUDIO•COMMAND•CENTER•25/50 is a voice evacuation control panel which can be used, with a variety of FACP's, to provide emergency audio messages. Two typical application examples follow.

ONE SPEAKER CIRCUIT

Single output zone, single input circuit (SEE FIGURE 1). A very basic application consists of one ACC•25/50 with one amplifier and a single speaker circuit. This configuration is suitable for small facilities requiring no more than 25 watts of output power. A single fire evacuation message will be generated during an alarm condition from the host FACP, or can be manually generated with a message push-button.

In this application example, the NAC from the host FACP is connected to CMD1. The CMD1 "out" terminals are then terminated with an end-of-line resistor for the FACP's Style Y NAC, or the terminals are wired back to the host FACP for a Style Z NAC. S3 DIP switches "1", "2", and "3" are set to OFF; this selection sends a 60-second message to the speaker circuit when the CMD1 input is activated. The S5 DIP switch "5" is set to OFF; this selection activates the CMD1 input by a reverse-polarity condition. CMD3, CMD4, and CMD5 inputs require end-of-line resistors.

In this application example, the system may also be **manually activated** from the keypad. Press the Building Speakers push-button, then press the Fire Message push-button. Alternately, use the microphone to make an announcement.

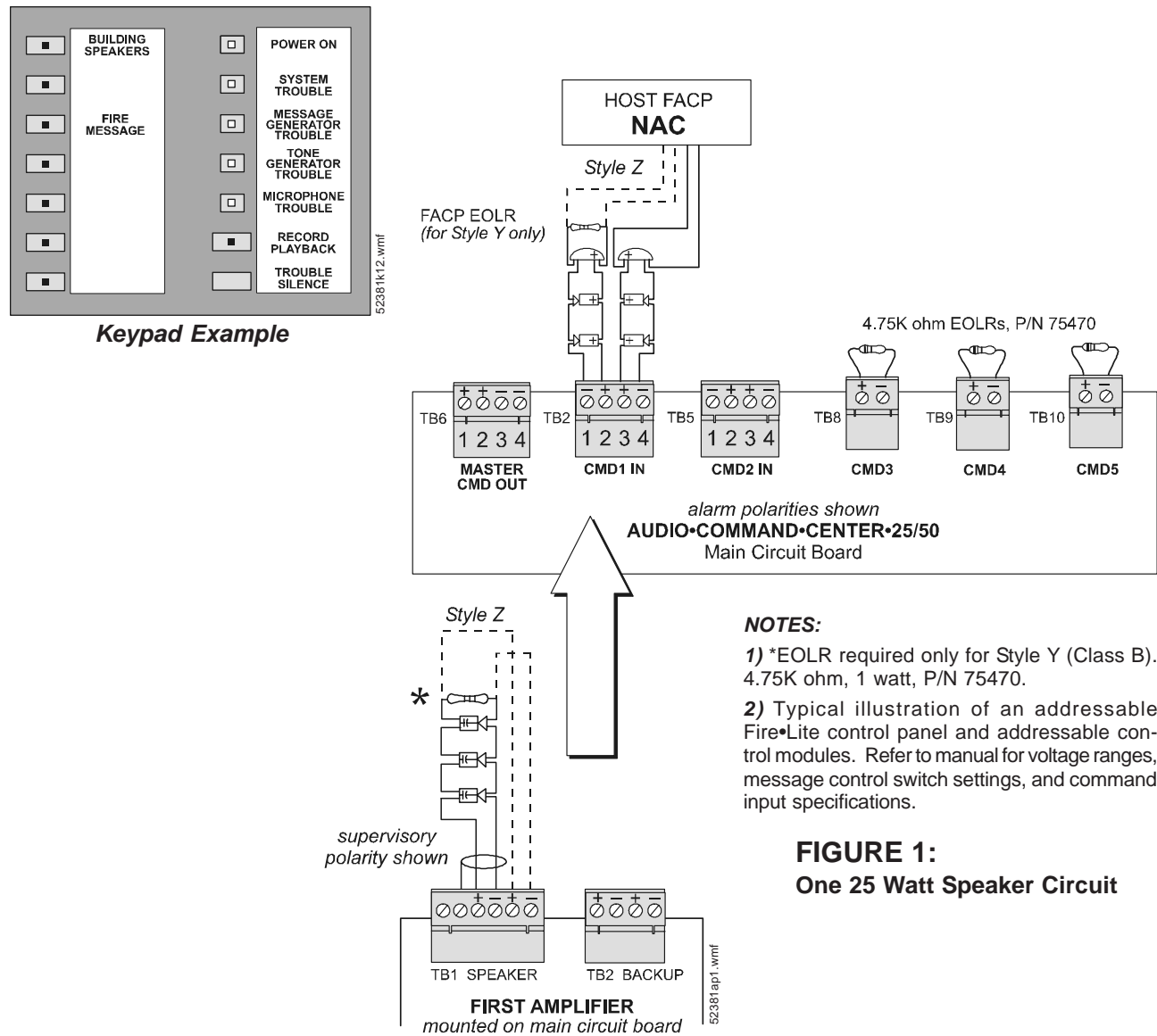

NOTES:

- 1) *EOLR required only for Style Y (Class B). 4.75K ohm, 1 watt, P/N 75470.
- 2) Typical illustration of an addressable Fire•Lite control panel and addressable control modules. Refer to manual for voltage ranges, message control switch settings, and command input specifications.

FIGURE 1:
One 25 Watt Speaker Circuit

TWO SPEAKER CIRCUITS

Dual output zone, dual input circuit — tone/voice message (SEE FIGURE 2). This application example consists of one ACC•25/50 with two speaker circuits and requires the installation of a second amplifier. This configuration is suitable for small facilities requiring no more than 50 watts of output power and a 60-second fire evacuation message.

In this application example, the addressable FACP directs tone or voice messages to either of the speaker circuits via the control modules connected to the CMD1 and CMD2 inputs. S3 DIP switches “1”, “2”, and “3” are set to OFF; this selection

configures CMD1/CMD2 to direct the Fire Message to the Auditorium Speakers or Classroom Speakers. The S5 DIP switches “5” and “6” are set to ON; these contact closures activate CMD1 (switch “5”) and CMD2 (switch “6”) inputs.

In this application example, the system may also be **manually activated** from the keypad. Press the Auditorium Speakers and/or Classroom Speakers push-button(s), then press the Fire Message push-button. Alternately, use the microphone to make an announcement. To **manually deactivate** a speaker circuit, press the activated (illuminated) output zone push-button.

