

CRF-300-6 Six Relay Control Module

One FireLite Place
Northford, CT 06472
Phone: 203.484.7161

SPECIFICATIONS

Normal Operating Voltage:	15-32 VDC	
Stand-By Current:	1.45 mA	
Alarm Current:	32 mA (assumes all six relays have been switched once and all six LEDs solid on)	Temperature Range:
32°F to 120°F (0°C to 49°C)		
Humidity:	10 to 93% Non-condensing	
Dimensions:	6.8"H × 5.8"W × 1.0"D	
Accessories:	CH-6 Chassis; BB-6 Cabinet; BB-2 Cabinet	
Wire Gauge:	12-18 AWG	
Relay Current:	30 mA/Relay Pulse (15.6 mS pulse duration) pulse under panel control	

CURRENT RATING	MAXIMUM VOLTAGE	LOAD DESCRIPTION	APPLICATION
3 A	30 VDC	Resistive	Non-coded
2 A	30 VDC	Resistive	Coded
.9 A	110 VDC	Resistive	Non-coded
.9 A	125 VDC	Resistive	Non-coded
.5 A	30 VDC	Inductive (L/R = 5ms)	Coded
1 A	30 VDC	Inductive (L/R = 2ms)	Coded
.3 A	125 VAC	Inductive (PF = .35)	Non-coded
1.5 A	25 VAC	Inductive (PF = .35)	Non-coded
.7 A	70.7 VAC	Inductive (PF = .35)	Non-coded
2 A	25 VAC	Inductive (PF = .35)	Non-coded



All relay switch contacts are shipped in the standby state (open) state, but may have transferred to the activated (closed) state during shipping. To ensure that the switch contacts are in their correct state, modules must be made to communicate with the panel before connecting circuits controlled by the module.

BEFORE INSTALLING

This information is included as a quick reference installation guide. Refer to the appropriate Fire•Lite control panel installation manual for detailed system information. If the modules will be installed in an existing operational system, inform the operator and local authority that the system will be temporarily out of service. Disconnect the power to the control panel before installing the modules. This system contains static sensitive components. Always ground yourself with a proper wrist strap before handling any circuits so that static charges are removed from the body. The module housing should also be grounded.

NOTICE: This manual should be left with the owner/user of this equipment.
GENERAL DESCRIPTION

The CRF-300-6 Six Relay Control Module is intended for use in an intelligent alarm system. Each module is intended for Form-C switching applications, which do not require wiring supervision for the load circuit. A single isolated set of dry relay contacts is provided for each module, which is capable of being wired for either normally open or normally closed for each operation. Each module has its own address. A pair of rotary code switches is used to set the address of the first module from 01 to 154. The remaining modules are automatically assigned to the next five higher addresses. Provisions are included for disabling a maximum of three unused modules to release the addresses to be used elsewhere. Each CRF-300-6 module also has panel controlled green LED indicators. The panel can cause the LEDs to blink, latch on, or latch off.

Contents include:

- (6) 1 × 3 Terminal Blocks
- (1) 1 × 4 Terminal Blocks
- (2) 11/4" Stand offs
- (4) Machine Screws
- (1) Shunt (NOTE: For the disable position, not more than one shunt shall be installed at the same time)
- (2) Nuts

COMPATIBILITY REQUIREMENTS

To ensure proper operation, this module shall be connected to a compatible Fire•Lite system control panel (list available from Fire•Lite).

COMPONENTS

Following are descriptions of the CRF-300-6 mounting frameworks. There are two mounting options for CRF-300-6 modules:

- Up to six CRF-300-6 modules can be installed on a CH-6 in a BB-6 cabinet
- One or two CRF-300-6 modules can be installed in a BB-2 cabinet

Chassis

The CH-6 chassis is used to mount CRF-300-6 modules in a BB-6 cabinet. It accommodates up to six CRF-300-6 modules in a single cabinet row three modules wide and two modules deep.

FIGURE 1. CH-6 CHASSIS:

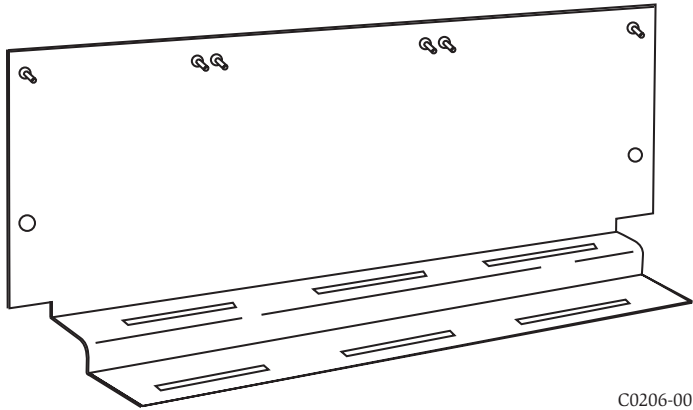

The BB-2 cabinet has a built-in chassis that will accommodate one or two CRF-300-6 modules.

FIGURE 2. BB-2 CABINET:

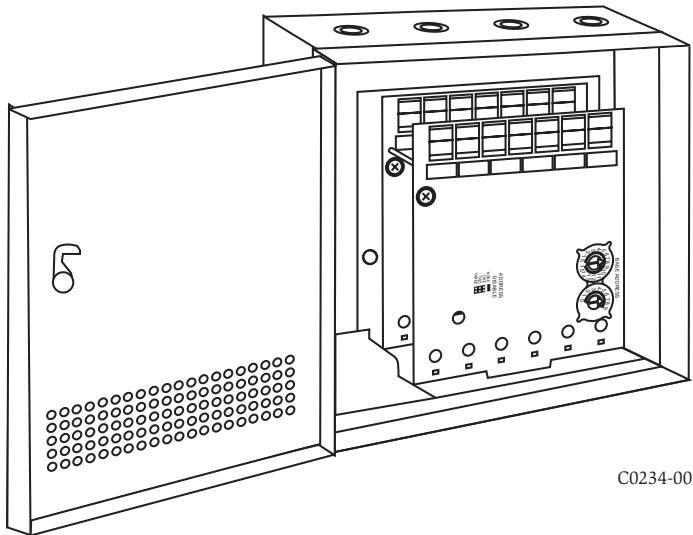

The front CRF-300-6 module positions of each chassis are offset below the rear CRF-300-6 module positions so that all of the status indicators are visible.

Cabinets

A BB-6 cabinet will house the CH-6 chassis with up to six CRF-300-6 modules installed on it. Refer to cabinet installation documents for dimensions.

The BB-2 cabinet houses one or two CRF-300-6 modules on the internal chassis that is part of the cabinet. Refer to cabinet installation documents for dimensions.

INSTALLATION STEPS

1. Cabinet Mounting

FIGURE 3. TYPICAL MOUNTING HOLE LOCATIONS:

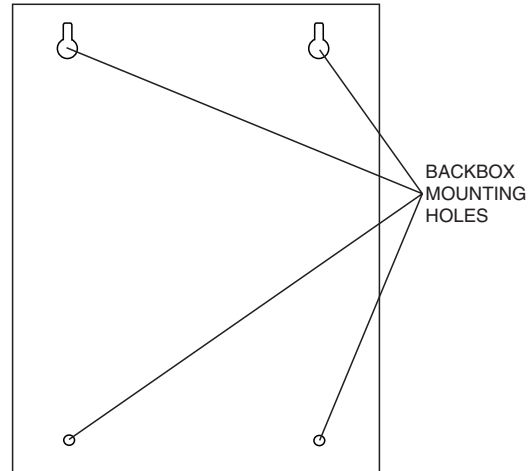

In a clean, dry area, mount the backbox using the four holes provided in the back surface of the cabinet.

2. Chassis Installation

The CH-6 chassis is mounted in the BB-6 cabinet. It is shipped with two self-threading screws, which are used to fasten the chassis to the back wall of the cabinet (see Figure 4).

FIGURE 4. MOUNTING THE CH-6 CHASSIS:

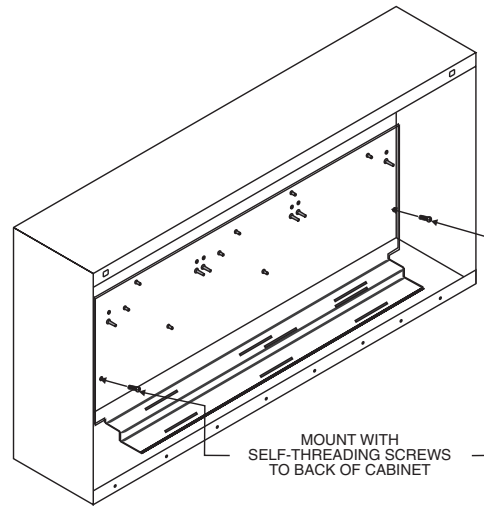

The BB-2 cabinet comes with the chassis already installed, so no mounting is necessary.

3. Module Installation

There are two methods for installing a module in the rear position of a chassis. Method one is for installation of a rear module only, when no module will be installed in front of it. Refer to Figure 5 for instructions. Method two is for installation of a rear module when another module will be installed in the chassis position in front of it. Refer to Figures 6a and 6b for method two. All necessary screws and standoffs are supplied with the modules.

FIGURE 5. INSTALLATION OF REAR MODULE ONLY, METHOD ONE:

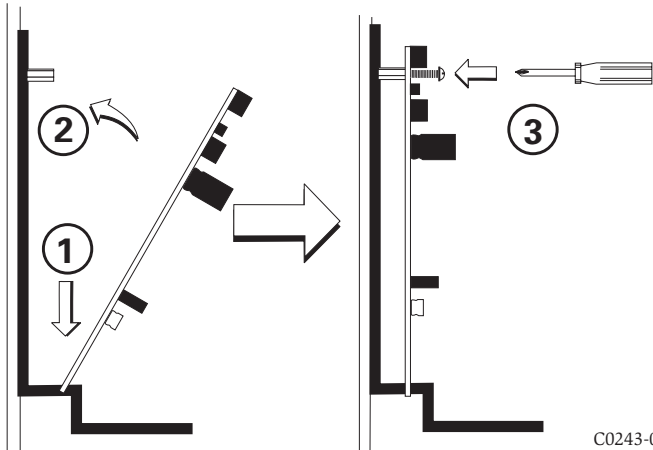

- Step 1: Insert the bottom of the CRF-300-6 module down into a rear slot on the chassis.
- Step 2: Carefully swing the upper edge of the board back towards the back of the chassis until it touches the two standoffs.
- Step 3: Align two 4-40 screws with the two standoffs and tighten.
- Step 4: Address and wire the modules according to the instructions in this manual.

The steps in Figures 6a and 6b describe and illustrate module installation when the rear chassis position and the position in front of it will be filled. Front position installation is possible only if the rear position is filled with a module.

FIGURE 6A. INSTALLATION OF CRF-300-6 MODULE IN A REAR CHASSIS POSITION, METHOD TWO:

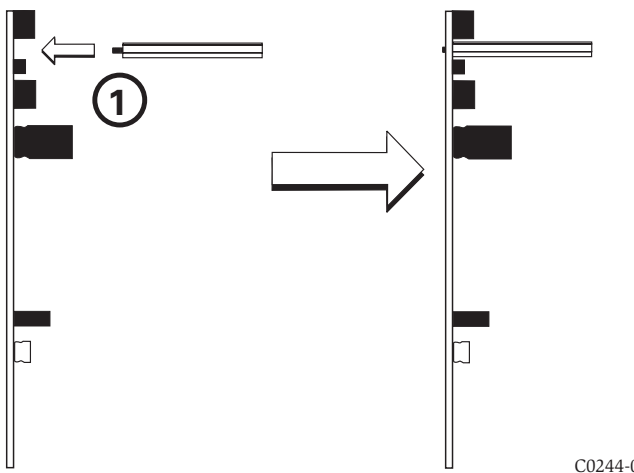

- Step 1: Insert the bottom edge of the CRF-300-6 module down into a rear slot of the chassis.

- Step 2: Carefully swing the bottom edge of the board towards the back of the board until it touches the short standoff attached to the chassis.

- Step 3: Align the long standoff with the short standoff and tighten.

FIGURE 6B. INSTALLATION OF CRF-300-6 MODULE IN FRONT CHASSIS POSITION:

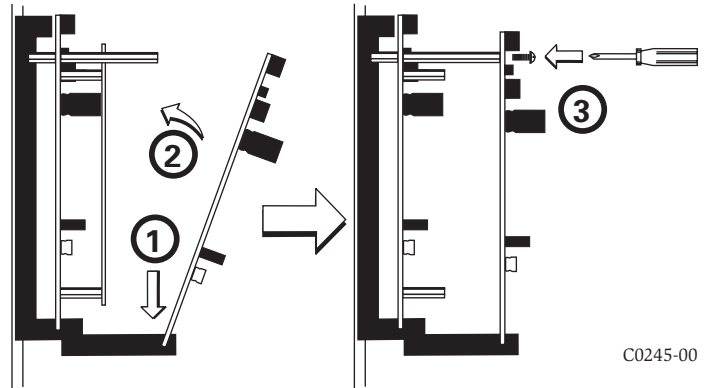

- Step 1: Insert the bottom edge of the CRF-300-6 module down into a front slot of the chassis.
- Step 2: Carefully swing the upper edge of the board towards the back of the chassis until it touches the 11/4 (31.75mm) standoffs installed on the rear module.
- Step 3: Align two 4-40 screws with the two standoffs and tighten.
- Step 4: Address and wire the modules according to the instructions in this manual.

WIRING

NOTE: All wiring must conform to applicable local codes, ordinances, and regulations.

1. Install module wiring in accordance with the job drawings and appropriate wiring diagrams.
2. Make electrical connections by stripping approximately 1/4" (6.35mm) of insulation from the end of the wire sliding the bare end of the wire under the clamping plate, and tightening the clamping plate screw.
3. Set the address on the modules per the job drawing. Use the rotary code switches to set the address of the first module (between 01 and 154). The remaining modules are automatically assigned to the next five higher addresses. For example, if the base address switch is set to 28, the next five modules will be addressed to 29, 30, 31, 32, and 33. DO NOT set the lowest address above 154, as the other modules will be assigned to nonexistent addresses.

NOTE: Some panels support extended addressing. In order to set the module above address 99 on compatible systems, carefully remove the stop on the upper rotary switch. If the panel does not support extended addressing, do not set the lowest address above 94.

4. A shunt is provided to disable a maximum of three unused modules. Modules are disabled from the highest address and work downward. If two modules are disabled, the lowest four addresses will be functional, while the highest two will be disabled. For example, if the shunt for Address Disable is placed on "two" and the base address switch is set to 28, the modules will be assigned to 28, 29, 30 and 31.

NOTE: Power must not be applied to the unit when changing functionality of the shunts.

FIGURE 7. WIRING AND PROGRAMMING THE CRF-300-6 MODULE:

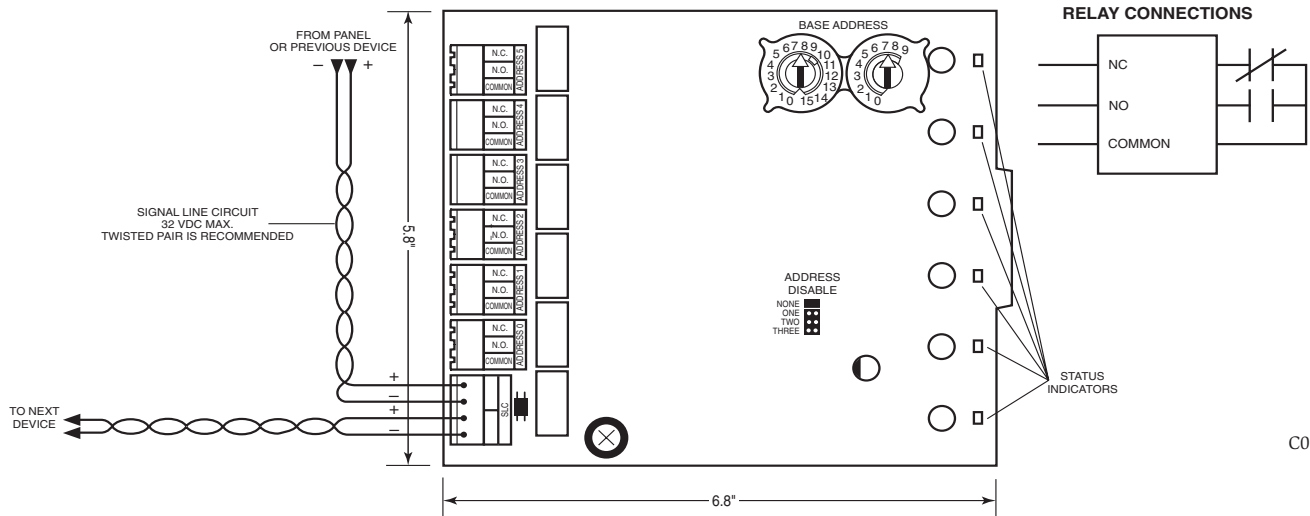

C0778-02

NOTES:

- The relay contacts on the CRF-300-6 may be connected to either a power-limited or non power-limited source, this wiring must remain separated by at least 1/4" (6.35 mm) from all power-limited wiring.
- Power-limited circuits must employ type FPL, FPLR, or FPLP cable as required by Article 760 of the NEC.
- For easier wiring, assign all power-limited wiring to one side rather than alternating with non power-limited.

PROGRAMMING

The CRF-300-6 module operates with the following Fire Alarm Control Panels:

- MS-9200
- MS-9600

FCC STATEMENT

This device complies with part 15 of the FCC Rules. Operation is subject to the following two conditions: (1) This device may not cause harmful interference, and (2) this device must accept any interference received, including interference that may cause undesired operation.

NOTE: This equipment has been tested and found to comply with the limits for a Class B digital device, pursuant to Part 15 of the FCC Rules. These limits are designed to provide reasonable protection against harmful interference in a residential installation. This equipment generates, uses and can radiate radio frequency energy and, if not installed and used in accordance with the instructions, may cause harmful interference to radio communications. However, there is no guarantee that interfer-

ence will not occur in a particular installation. If this equipment does cause harmful interference to radio or television reception, which can be determined by turning the equipment off and on, the user is encouraged to try to correct the interference by one or more of the following measures:

- Reorient or relocate the receiving antenna.
- Increase the separation between the equipment and receiver.
- Connect the equipment into an outlet on a circuit different from that to which the receiver is connected.
- Consult the dealer or an experienced radio/TV technician for help.