



# **Firefighter's Telephone ECC-FFT Instruction Manual**

Document LS10031-000FL-E  
9/4/2013 Rev: **B**

P/N LS10031-000FL-E:B

ECN 13-707

# Fire Alarm & Emergency Communication System Limitations

*While a life safety system may lower insurance rates, it is not a substitute for life and property insurance!*

**An automatic fire alarm system**—typically made up of smoke detectors, heat detectors, manual pull stations, audible warning devices, and a fire alarm control panel (FACP) with remote notification capability—can provide early warning of a developing fire. Such a system, however, does not assure protection against property damage or loss of life resulting from a fire.

**An emergency communication system**—typically made up of an automatic fire alarm system (as described above) and a life safety communication system that may include an autonomous control unit (ACU), local operating console (LOC), voice communication, and other various interoperable communication methods—can broadcast a mass notification message. Such a system, however, does not assure protection against property damage or loss of life resulting from a fire or life safety event.

The Manufacturer recommends that smoke and/or heat detectors be located throughout a protected premises following the recommendations of the National Fire Protection Association Standard 72 (NFPA 72), manufacturer's recommendations, State and local codes, and the recommendations contained in the Guide for Proper Use of System Smoke Detectors, which is made available at no charge to all installing dealers. This document can be found at <http://www.systemsensor.com/appguides/>. A study by the Federal Emergency Management Agency (an agency of the United States government) indicated that smoke detectors may not go off in as many as 35% of all fires. While fire alarm systems are designed to provide early warning against fire, they do not guarantee warning or protection against fire. A fire alarm system may not provide timely or adequate warning, or simply may not function, for a variety of reasons:

**Smoke detectors** may not sense fire where smoke cannot reach the detectors such as in chimneys, in or behind walls, on roofs, or on the other side of closed doors. Smoke detectors also may not sense a fire on another level or floor of a building. A second-floor detector, for example, may not sense a first-floor or basement fire.

**Particles of combustion or "smoke"** from a developing fire may not reach the sensing chambers of smoke detectors because:

- Barriers such as closed or partially closed doors, walls, chimneys, even wet or humid areas may inhibit particle or smoke flow.
- Smoke particles may become "cold," stratify, and not reach the ceiling or upper walls where detectors are located.
- Smoke particles may be blown away from detectors by air outlets, such as air conditioning vents.
- Smoke particles may be drawn into air returns before reaching the detector.

The amount of "smoke" present may be insufficient to alarm smoke detectors. Smoke detectors are designed to alarm at various levels of smoke density. If such density levels are not created by a developing fire at the location of detectors, the detectors will not go into alarm.

Smoke detectors, even when working properly, have sensing limitations. Detectors that have photoelectronic sensing chambers tend to detect smoldering fires better than flaming fires, which have little visible smoke. Detectors that have ionizing-type sensing chambers tend to detect fast-flaming fires better than smoldering fires. Because fires develop in different ways and are often unpredictable in their growth, neither type of detector is necessarily best and a given type of detector may not provide adequate warning of a fire.

Smoke detectors cannot be expected to provide adequate warning of fires caused by arson, children playing with matches (especially in bedrooms), smoking in bed, and violent explosions

(caused by escaping gas, improper storage of flammable materials, etc.).

**Heat detectors** do not sense particles of combustion and alarm only when heat on their sensors increases at a predetermined rate or reaches a predetermined level. Rate-of-rise heat detectors may be subject to reduced sensitivity over time. For this reason, the rate-of-rise feature of each detector should be tested at least once per year by a qualified fire protection specialist. Heat detectors are designed to protect property, not life.

**IMPORTANT! Smoke detectors** must be installed in the same room as the control panel and in rooms used by the system for the connection of alarm transmission wiring, communications, signaling, and/or power. If detectors are not so located, a developing fire may damage the alarm system, compromising its ability to report a fire.

**Audible warning devices such as bells, horns, strobes, speakers and displays** may not alert people if these devices are located on the other side of closed or partly open doors or are located on another floor of a building. Any warning device may fail to alert people with a disability or those who have recently consumed drugs, alcohol, or medication. Please note that:

- An emergency communication system may take priority over a fire alarm system in the event of a life safety emergency.
- Voice messaging systems must be designed to meet intelligibility requirements as defined by NFPA, local codes, and Authorities Having Jurisdiction (AHJ).
- Language and instructional requirements must be clearly disseminated on any local displays.
- Strobes can, under certain circumstances, cause seizures in people with conditions such as epilepsy.
- Studies have shown that certain people, even when they hear a fire alarm signal, do not respond to or comprehend the meaning of the signal. Audible devices, such as horns and bells, can have different tonal patterns and frequencies. It is the property owner's responsibility to conduct fire drills and other training exercises to make people aware of fire alarm signals and instruct them on the proper reaction to alarm signals.
- In rare instances, the sounding of a warning device can cause temporary or permanent hearing loss.

**A life safety system** will not operate without any electrical power. If AC power fails, the system will operate from standby batteries only for a specified time and only if the batteries have been properly maintained and replaced regularly.

**Equipment used in the system** may not be technically compatible with the control panel. It is essential to use only equipment listed for service with your control panel.

**Telephone lines** needed to transmit alarm signals from a premises to a central monitoring station may be out of service or temporarily disabled. For added protection against telephone line failure, backup radio transmission systems are recommended.

**The most common cause** of life safety system malfunction is inadequate maintenance. To keep the entire life safety system in excellent working order, ongoing maintenance is required per the manufacturer's recommendations, and UL and NFPA standards. At a minimum, the requirements of NFPA 72 shall be followed. Environments with large amounts of dust, dirt, or high air velocity require more frequent maintenance. A maintenance agreement should be arranged through the local manufacturer's representative. Maintenance should be scheduled monthly or as required by National and/or local fire codes and should be performed by authorized professional life safety system installers only. Adequate written records of all inspections should be kept.

Limit-D-1-2013

# Installation Precautions

*Adherence to the following will aid in problem-free installation with long-term reliability:*

**WARNING - Several different sources of power can be connected to the fire alarm control panel.** Disconnect all sources of power before servicing. Control unit and associated equipment may be damaged by removing and/or inserting cards, modules, or interconnecting cables while the unit is energized. Do not attempt to install, service, or operate this unit until manuals are read and understood.

**CAUTION - System Re-acceptance Test after Software Changes:** To ensure proper system operation, this product must be tested in accordance with NFPA 72 after any programming operation or change in site-specific software. Re-acceptance testing is required after any change, addition or deletion of system components, or after any modification, repair or adjustment to system hardware or wiring. All components, circuits, system operations, or software functions known to be affected by a change must be 100% tested. In addition, to ensure that other operations are not inadvertently affected, at least 10% of initiating devices that are not directly affected by the change, up to a maximum of 50 devices, must also be tested and proper system operation verified.

**This system** meets NFPA requirements for operation at 0-49° C/32-120° F and at a relative humidity 93% ± 2% RH (non-condensing) at 32°C ± 2°C (90°F ± 3°F). However, the useful life of the system's standby batteries and the electronic components may be adversely affected by extreme temperature ranges and humidity. Therefore, it is recommended that this system and its peripherals be installed in an environment with a normal room temperature of 15-27° C/60-80° F.

**Verify that wire sizes are adequate** for all initiating and indicating device loops. Most devices cannot tolerate more than a 10% I.R. drop from the specified device voltage.

**Like all solid state electronic devices,** this system may operate erratically or can be damaged when subjected to lightning induced transients. Although no system is completely immune from lightning transients and interference, proper grounding will reduce susceptibility. Overhead or outside aerial wiring is not recommended, due to an increased susceptibility to nearby lightning strikes. Consult with the Technical Services Department if any problems are anticipated or encountered.

**Disconnect AC power and batteries** prior to removing or inserting circuit boards. Failure to do so can damage circuits.

**Remove all electronic assemblies** prior to any drilling, filing, reaming, or punching of the enclosure. When possible, make all cable entries from the sides or rear. Before making modifications, verify that they will not interfere with battery, transformer, or printed circuit board location.

**Do not tighten screw terminals** more than 9 in-lbs. Overtightening may damage threads, resulting in reduced terminal contact pressure and difficulty with screw terminal removal.

**This system contains static-sensitive components.** Always ground yourself with a proper wrist strap before handling any circuits so that static charges are removed from the body. Use static suppressive packaging to protect electronic assemblies removed from the unit.

**Follow the instructions** in the installation, operating, and programming manuals. These instructions must be followed to avoid damage to the control panel and associated equipment. FACP operation and reliability depend upon proper installation.

Precau-D1-9-2005

## FCC Warning

**WARNING:** This equipment generates, uses, and can radiate radio frequency energy and if not installed and used in accordance with the instruction manual may cause interference to radio communications. It has been tested and found to comply with the limits for class A computing devices pursuant to Subpart B of Part 15 of FCC Rules, which is designed to provide reasonable protection against such interference when devices are operated in a commercial environment. Operation of this equipment in a residential area is likely to cause interference, in which case the user will be required to correct the interference at his or her own expense.

## Canadian Requirements

This digital apparatus does not exceed the Class A limits for radiation noise emissions from digital apparatus set out in the Radio Interference Regulations of the Canadian Department of Communications.

Le présent appareil numérique n'émet pas de bruits radioélectriques dépassant les limites applicables aux appareils numériques de la classe A prescrites dans le Règlement sur le brouillage radioélectrique édicté par le ministère des Communications du Canada.

LiteSpeed™ is a trademark; and FireLite® Alarms is a registered trademark of Honeywell International Inc. Microsoft® and Windows® are registered trademarks of the Microsoft Corporation.

©2013 by Honeywell International Inc. All rights reserved. Unauthorized use of this document is strictly prohibited.

## Software Downloads

In order to supply the latest features and functionality in fire alarm and life safety technology to our customers, we make frequent upgrades to the embedded software in our products. To ensure that you are installing and programming the latest features, we strongly recommend that you download the most current version of software for each product prior to commissioning any system. Contact Technical Support with any questions about software and the appropriate version for a specific application.

## Documentation Feedback

Your feedback helps us keep our documentation up-to-date and accurate. If you have any comments or suggestions about our online Help or printed manuals, you can email us.

Please include the following information:

- Product name and version number (if applicable)
- Printed manual or online Help
- Topic Title (for online Help)
- Page number (for printed manual)
- Brief description of content you think should be improved or corrected
- Your suggestion for how to correct/improve documentation

Send email messages to:

**FireSystems.TechPubs@honeywell.com**

Please note this email address is for documentation feedback only. If you have any technical issues, please contact Technical Services.

# Table of Contents

<b>Section 1: Product Description .....</b>	<b>7</b>
1.1: Features.....	7
1.2: Optional Accessories .....	7
1.3: Compatible Devices.....	7
1.4: ECC-FFT Board Layout .....	8
1.5: Electrical Specifications .....	9
1.5.1: Power Requirements.....	9
1.5.2: Current Ratings.....	9
1.5.3: Wiring Specifications .....	10
<b>Section 2: Installation.....</b>	<b>11</b>
2.1: Mounting Options .....	11
2.2: Backbox Installation .....	11
2.3: Installing the ECC-FFT .....	13
2.3.1: Operating Power .....	13
2.3.2: DIP switch settings on ECC-FFT .....	13
DIP Switch.....	13
2.4: UL Power-limited Wiring Requirements .....	14
2.5: ECC-FFT Fire Fighter Telephone Module Connection .....	15
2.6: FPJ-F Installation.....	16
2.7: SLC Device Installation.....	17
2.7.1: List of SLC Devices .....	17
2.7.2: Maximum Number of Devices .....	17
2.7.3: Wiring Requirements for SLC Device .....	17
Wiring SLC in Style 4 (Class B) Configuration.....	17
Wiring SLC Devices in Style 6 & 7 (Class A) Configuration .....	19
2.7.4: Addressing MMF-301 SLC Devices .....	19
2.8: Audio Phone Circuit Installation .....	20
2.8.1: Maximum Number of Devices .....	20
2.8.2: Wiring Requirements for the Audio Telephone Circuit .....	20
Single Phone Jack Audio Circuit in Class B Configuration.....	21
Single Phone Jack Audio Circuit in Class A Configuration.....	22
Multi-Phone Jack Audio Circuit in Class B Configuration.....	23
Multi-Phone Jack Audio Circuit in Class A Configuration.....	24
Telephone Jack Only Audio Circuit.....	25
<b>Section 3: System Operation .....</b>	<b>27</b>
3.1: Push-button Operations .....	27
3.2: LED Operations .....	27
3.3: Autoprogram Operation.....	28

This control panel has been designed to comply with standards set forth by the following regulatory agencies:

- Underwriters Laboratories/Underwriters Laboratories Canada
- National Fire Protection Association

**Before proceeding, the installer should be familiar with the following documents.**



#### **NFPA Standards**

This Fire Alarm Control Panel complies with the following NFPA Standards:

NFPA 72 National Fire Alarm Code

Note: Audible signal appliances used in public mode applications, are required to have minimum sound levels of 75 dBA at 10 feet (3 meters) and a maximum level of 120 dBA at the minimum hearing distance from the audible appliance.

To ensure that the appliance is clearly heard, the audible appliance sound level must be at least 15 dBA above the average ambient sound level or 5 dBA above the maximum sound level with a duration of at least 60 seconds, depending on which level is greater, with the sound level being measured 5 feet (1.5 meters) above the floor.

#### **Underwriters Laboratories Documents:**

UL 38 Manually Actuated Signaling Boxes

UL 464 Audible Signaling Appliances

UL 864 Standard for Control Units for Fire Protective Signaling Systems

UL 1480 Speakers for Fire Protective Signaling Systems

UL 1481 Power Supplies for Fire Protective Signaling Systems

UL 1638 Visual Signaling Appliances

UL 1711 Amplifiers for Fire Protective Signaling Systems

UL 1971 Signaling Devices for Hearing Impaired

UL 2572 Communication and Control Units for Mass Notification Systems

NEC Article 250 Grounding

NEC Article 300 Wiring Methods

NEC Article 760 Fire Protective Signaling Systems

UFC Unified Facilities Criteria UFC 4-021-01: Mass Notification Systems

Applicable Local and State Building Codes

Requirements of the Local Authority Having Jurisdiction (LAHJ)

#### **Fire•Lite Documents**

Fire•Lite Device Compatibility Document

Document #15384

ECC-50/100 Manual

Document #LS10001-000FL-E

ECC-50/125DA Manual

Document #LS10027-000FL-E

MS-9200UDLS Series Manual

Document #52750

MS-9600(UD)LS Technical Manual

Document #52646

FCPS-24FS6/8 Field Charger/Power Supply

Document #51883

HP300ULX Power Supply

Document # 52386

This product has been certified to comply with the requirements in the Standard for Control Units and Accessories for Fire Alarm Systems, UL 864, 9th Edition. Operation of this product with products not tested for UL 864, 9th Edition has not been evaluated. Such operation requires the approval of the local Authority Having Jurisdiction (AHJ).



# Section 1: Product Description

An ECC-FFT Fire Fighter Telephone System provides supervision, annunciation, and control for local and remote telephone handsets. The ECC-FFT with keypad, provides indications of phone activation, and corresponding trouble conditions.

## 1.1 Features

- One Form-C system trouble relay - TB6
- ECC-FFT Fire Fighter Telephone module for control and annunciation of up to 24 remote telephone jacks
- A maximum of ten (10) Fire Fighter Remote Handsets (FHS-F) can be used at one time to communicate over the telephone circuit connected to the ECC-FFT
- Fire Fighter Phone Jack (FPJ-F) provides a plug-in location for the FHS-F
- Fire Fighter Handset Cabinet (FHSC-RF/SF) is used to store up to five (5) Fire Fighter Handsets (FHS-F)
- System Status LEDs

## 1.2 Optional Accessories

This manual also contains information on how to install the following compatible accessories with the FFT series equipment:

Model Number	Description
FPJ-F	Remote Phone Jack
FHS-F	Fire Fighters Remote Handset
FHSC-RF	Fire Fighters Handset Cabinet Recessed
FHSC-SF	Fire Fighters Handset Cabinet Surface Mount
MMF-301	Addressable Mini-Monitor Module
I300	SLC Line Isolation Module

## 1.3 Compatible Devices

Table 1.1 lists the available FireLite fire alarm control panels/systems and power supplies compatible with the ECC-FFT.

Model	Manual PN
ECC-50/100 Emergency Command Center	LS10001-000FL-E
MS-9200UDLS Addressable Fire Alarm Control Panel	52750
MS-9600(UD)LS Addressable Fire Alarm Control Panel	52646
FCPS-24FS6/8 Field Charger/Power Supply	51883

**Table 1.1 Compatible Powering Devices**

# 1.4 ECC-FFT Board Layout

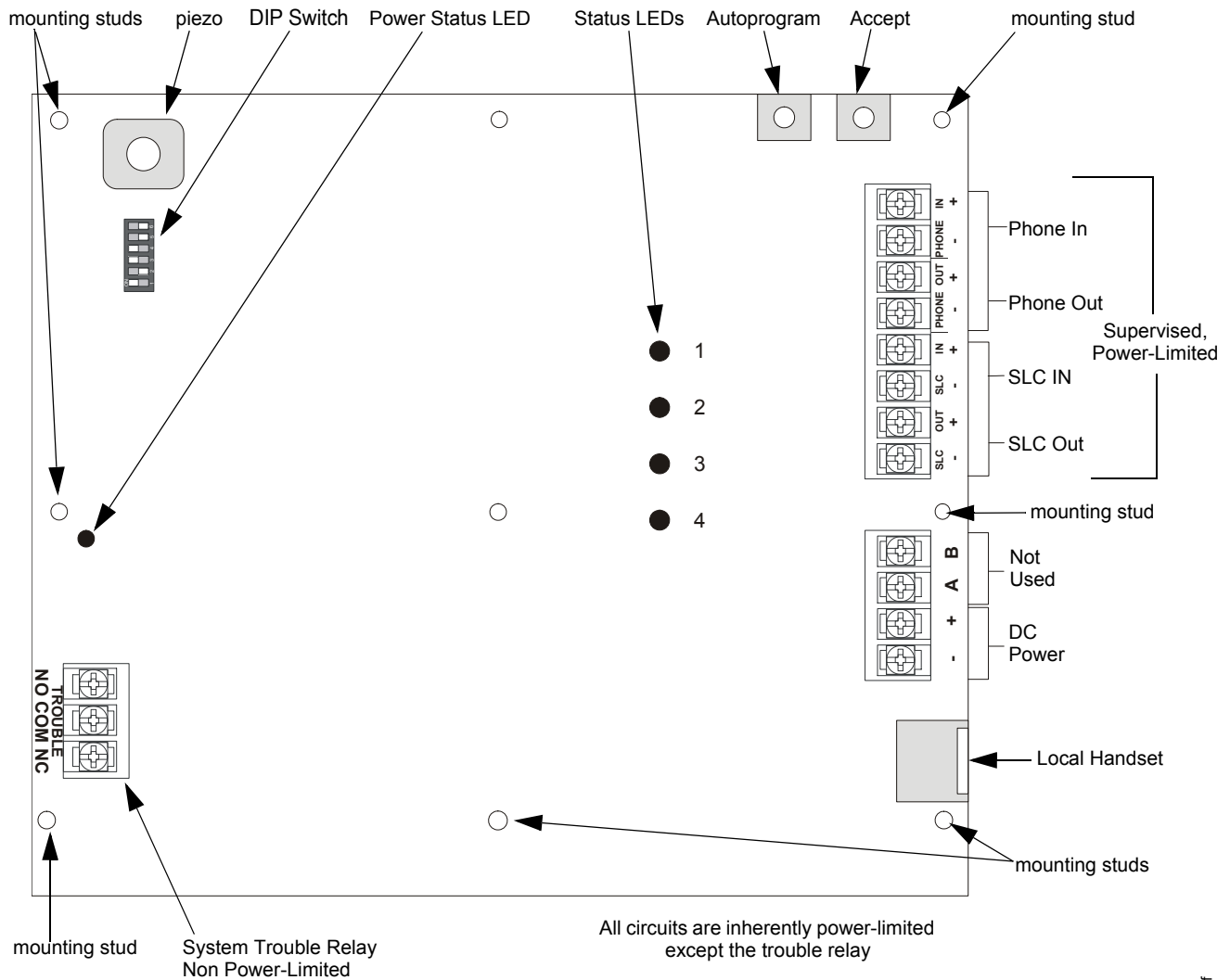

ffbird.wmf

**Figure 1.1 Back view of ECC-FFT**

Figure 1.1 above shows the circuit board that attaches to the cabinet. If you should need to remove the board assembly for repair, remove the seven mounting nuts which hold the assembly in the cabinet. Then lift the control board out of the cabinet.



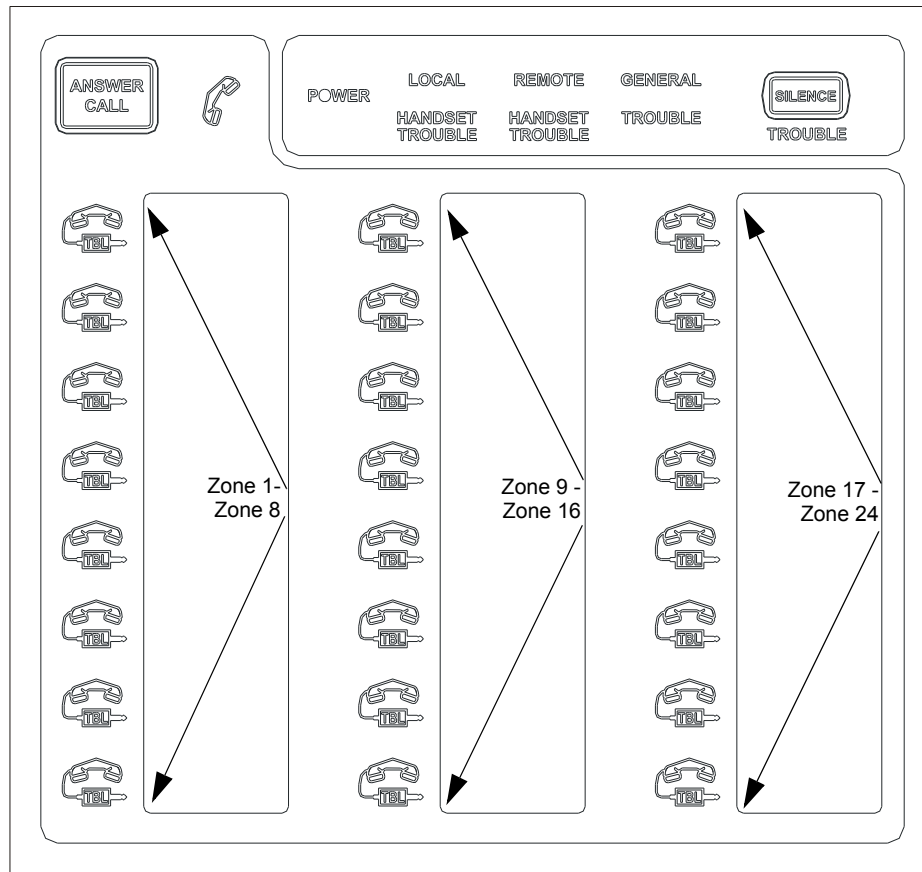

Figure 1.2 ECC-FFT Keypad

## 1.5 Electrical Specifications

### 1.5.1 Power Requirements

Voltage for the ECC-FFT must be a UL-listed, power-limited, filtered, non-resettable nominal 24 VDC source. The voltage source must be within the range of 17-29 VDC.

Circuits	Voltage	Current
SLC Circuit	32 V	150 mA
Audio Circuits	17 V	53 mA
Trouble Relay	12 VDC	1 A

Table 1.2 Electrical Ratings

### 1.5.2 Current Ratings

Maximum current ratings for determining backup battery requirements for alarm (active) and standby conditions over the input voltage range of 17-29 VDC are shown in Table 1.3 below.

	Active	Standby
ECC-FFT	230 mA	120 mA

Table 1.3 ECC-FFT Current Draw

### 1.5.3 Wiring Specifications

Induced noise (transfer of electrical energy from one wire to another) can interfere with telephone communication or cause false alarms. To avoid induced noise, follow these guidelines:

- Isolate input wiring from high current output and power wiring. Do not pull one multi-conductor cable for the entire panel. Instead, separate the wiring as follows:
  - SLC Loops
  - Relay Circuit
  - Audio Circuits
- Do not pull wires from different circuits (listed above) through the same conduit. If you must run them together, do so for as short a distance as possible or use shielded cable. Twisted, shielded wire on the Audio Circuits is recommended for maximum protection against EMI and AFI emissions and susceptibility. Connect the shield to earth ground at the panel. You must route high and low voltages separately.
- Route the wiring around the inside perimeter of the cabinet. It should not cross the circuit board where it could induce noise into the sensitive microelectronics or pick up unwanted RF noise from the high speed circuits. See Figure 2.4 for an example.
- High frequency noise, such as that produced by the inductive reactance of a speaker or bell, can also be reduced by running the wire through ferrite shield beads or by wrapping it around a ferrite toroid.

# Section 2: Installation

## 2.1 Mounting Options

The cabinet may be semi-flush or surface mounted. The cabinet mounts using three key slots at the top of the backbox and two additional 0.250" diameter holes located at the bottom.

Carefully unpack the system and check for shipping damage. Mount the cabinet in a clean, dry, vibration-free area where extreme temperatures are not encountered. The area should be readily accessible with sufficient room to easily install and maintain the panel. Locate the top of the cabinet approximately five feet above the floor with the hinge mounting on the left. Determine the number of conductors required for the devices to be installed. Sufficient knockouts are provided for wiring convenience. Select the appropriate knockout(s) and pull the required conductors into the box. Note that knockouts are also located on the back of the cabinet. All wiring should be in accordance with the National and/or Local codes for fire alarm systems.

## 2.2 Backbox Installation



---

**CAUTION: STATIC SENSITIVE COMPONENTS**

THE CIRCUIT BOARD CONTAINS STATIC-SENSITIVE COMPONENTS. ALWAYS GROUND YOURSELF WITH A PROPER WRIST STRAP BEFORE HANDLING ANY BOARDS SO THAT STATIC CHARGES ARE REMOVED FROM THE BODY. USE STATIC SUPPRESSIVE PACKAGING TO PROTECT ELECTRONIC ASSEMBLIES.

---

1. Open the door and lift the door off the pin hinges.
2. Loosen the two (2) screws that secure the dress panel to the backbox. Then, lift up to swing the dress panel open.
3. Disconnect the ground wire from the dress panel.
4. Lift the dress panel up and gently pull the lower hinge out of the backbox. Gently pull down to remove the top hinge. Store the dress panel in a safe place.

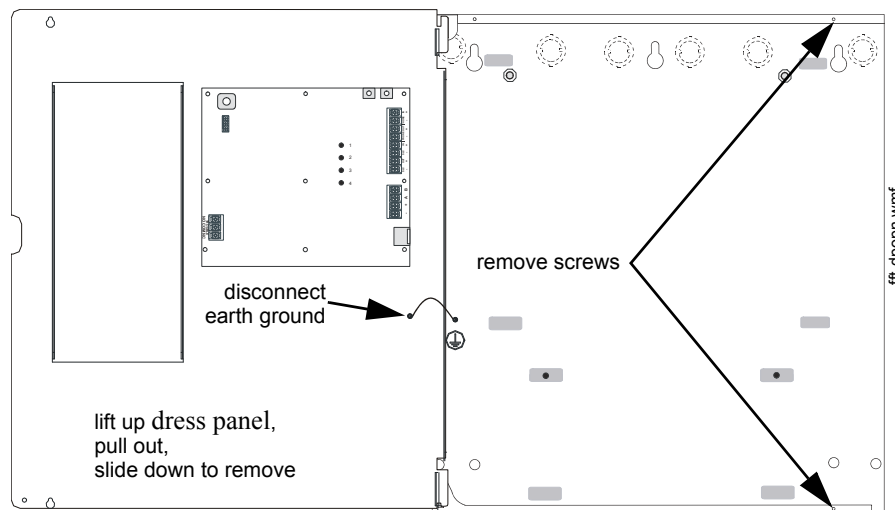

**Figure 2.1 Dress Panel Removal**

5. Mark and predrill hole in the wall for the center top keyhole mounting bolt using the dimensions illustrated in Figure 2.2 on page 12.
6. Install center top fastener in the wall with the screw head protruding.

7. Place backbox over the top screw, level and secure.
8. Mark and drill the left and right upper and lower mounting holes.  
Note: Outer holes (closest to sidewall) are used for 16" O.C. stud mounting.
9. Install remaining fasteners and tighten.
10. Carefully reinstall the chassis assembly and dress panel by reversing the steps above. Use appropriate precautions to prevent damage to components due to static discharge.
11. Draw wires through the respective knockout locations.

An optional Trim Ring (P/N TR-CE) is available for semi-flush mount installations.

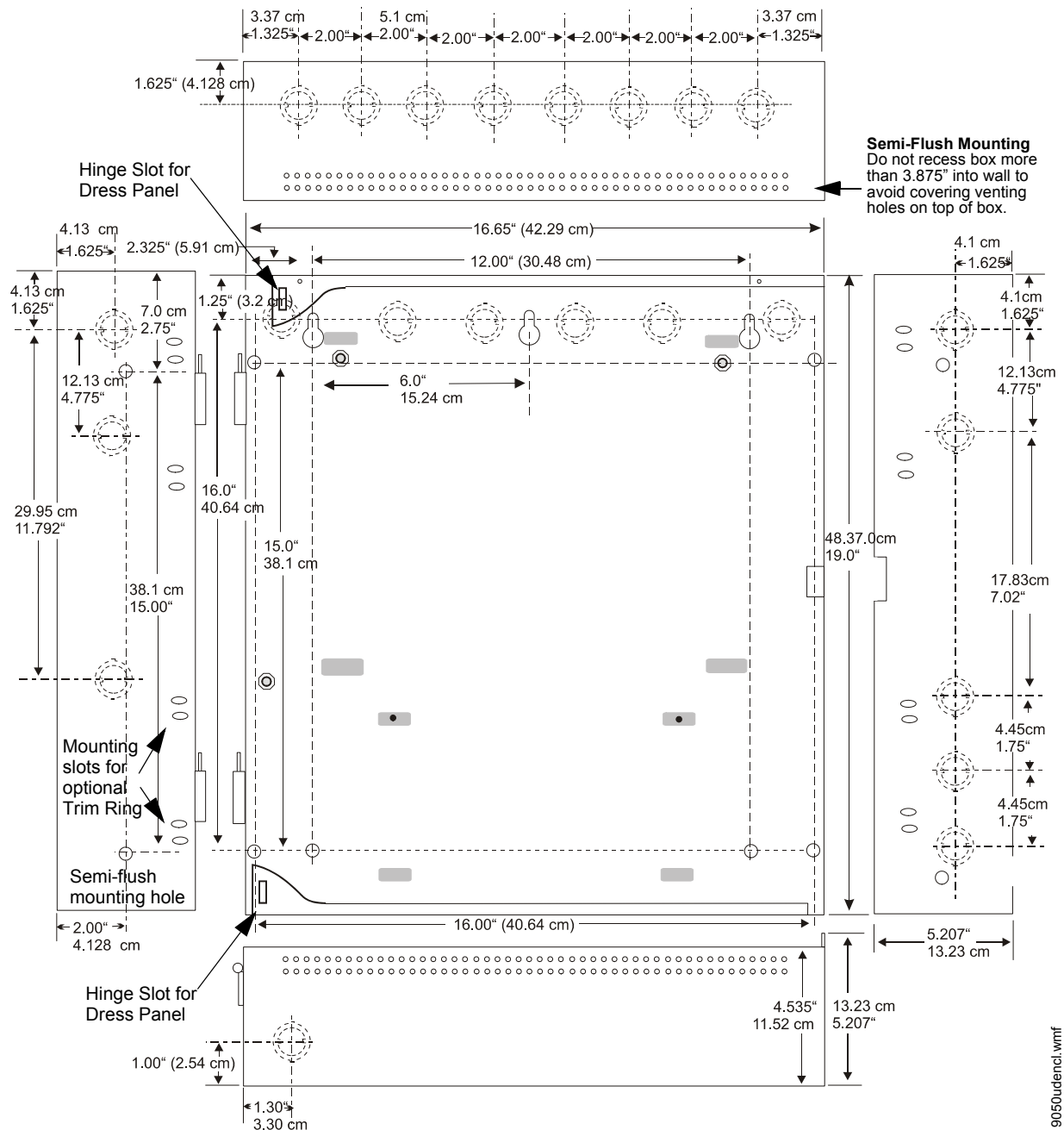

Figure 2.2 Cabinet Dimensions & Knockout Locations

## 2.3 Installing the ECC-FFT

### 2.3.1 Operating Power

Connect the ECC-FFT to the appropriate DC power source. See Section 1.3 for compatible equipment and Section 1.5 for power requirements.

### 2.3.2 DIP switch settings on ECC-FFT

Use the on-board DIP switch to assign the configuration setting to the ECC-FFT.

1. Refer to Figure 2.3 for location of the DIP switches on the ECC-FFT board.
2. Configure the ECC-FFT using the dip switch settings in Table 2.1. Add SLC modules to the system through Autoprogram feature. See Section 3.3 for Autoprogram Operation.

#### DIP Switch



Figure 2.3 DIP Switch

DIP Switch	ON	OFF
1	SLC Devices Installed	SLC Devices not Installed
2	Trouble Piezo Enabled	Trouble Piezo Disabled
3	SLC Class A Supervision	SLC Class B Supervision
4	Phone Circuit Class A Supervision	Phone Circuit Class B Supervision
5	Not Used	Leave in OFF position
6	Not Used	Leave in OFF position

Table 2.1 ECC-FFT DIP Switch Configurations

## 2.4 UL Power-limited Wiring Requirements

Power-limited and nonpower-limited circuit wiring must remain separated in the cabinet. All power-limited circuit wiring must remain at least 0.25" (6.35 mm) away from any nonpower-limited circuit wiring and nonpower-limited circuit wiring must enter and exit the cabinet through different knockouts and/or conduits. A typical wiring diagram for the ECC-FFT is shown below.

Note: The dress panel is shown swung open for illustration purposes only.

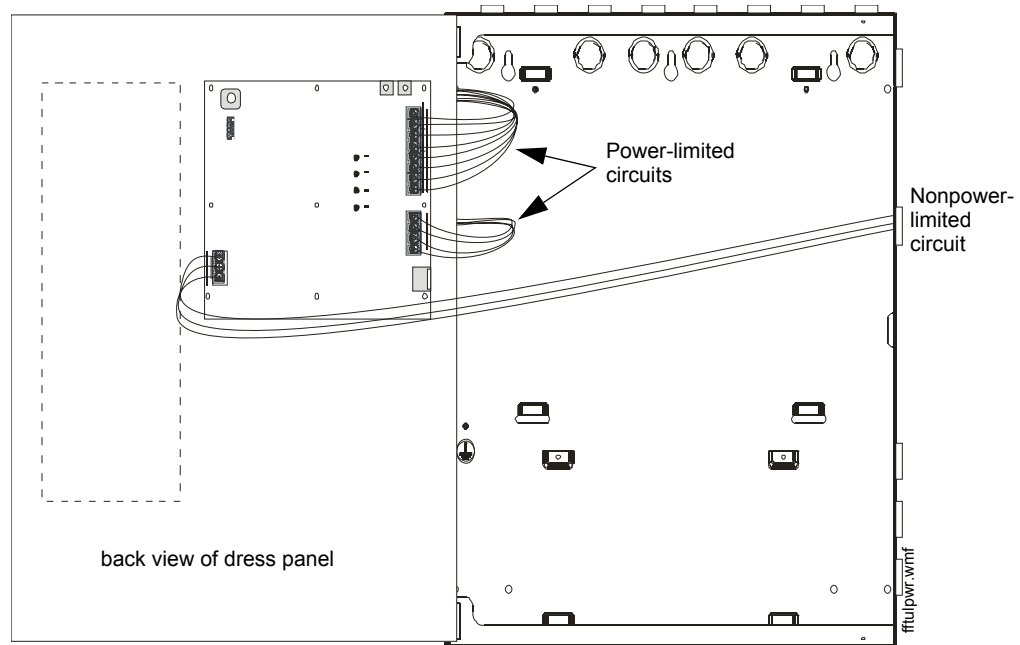

Figure 2.4 UL Power-Limited Wiring Requirements

## 2.5 ECC-FFT Fire Fighter Telephone Module Connection

The ECC-FFT provides connection for a single Class B or Class A telephone audio circuit. See page 21 through page 26 for examples of audio zone configurations. An MMF-301 monitor module can be used to monitor the connection of the Fire Fighter Telephone remote handset (FHS-F) into the FPJ-F, which is then displayed on the ECC-FFT active zone LED during the Autoprogram feature.

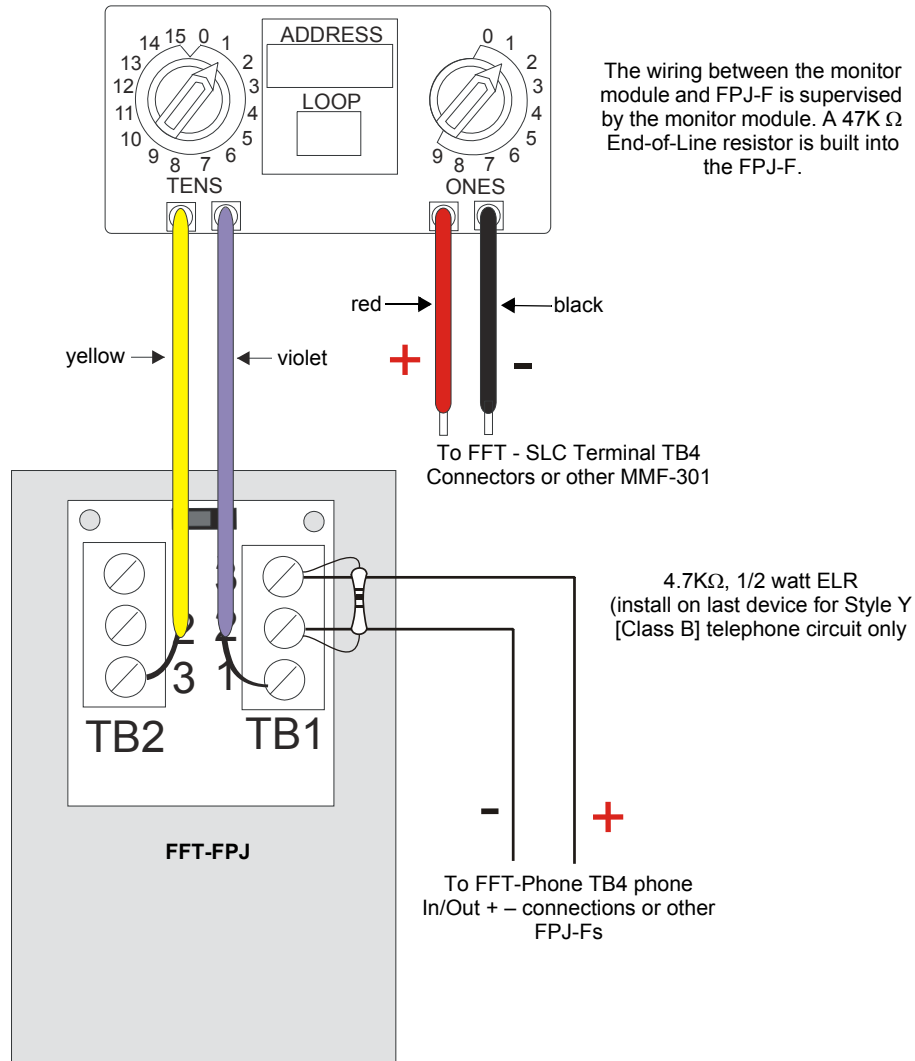

Figure 2.5 ECC-FFT Connections

## 2.6 FPJ-F Installation

The FPJ-F Firefighter Phone Jack mounts to a single-gang electrical box (4 x 2 1/8 x 2 1/2) or, when the addressable mini-monitor module is installed with it, a deep single-gang electrical box (4" x 2 1/8" x 3 1/4").

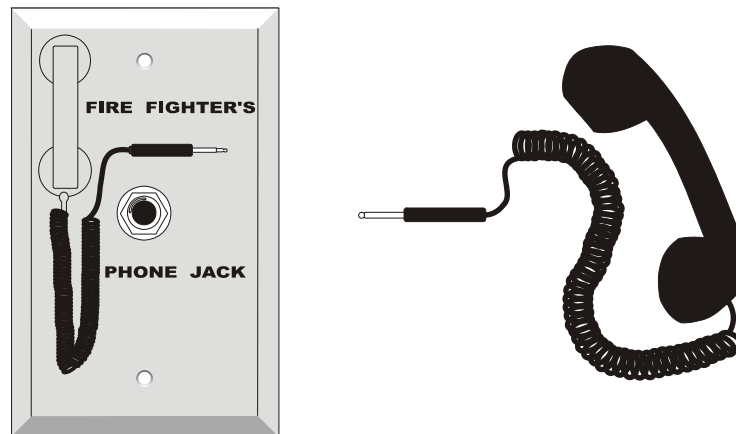

Figure 2.6 FPJ-F (Phone Jack) and FHS-F (Handset)

Connect the telephone audio loop between the FPJ-F and FFT as detailed below. All circuits are power-limited and supervised.

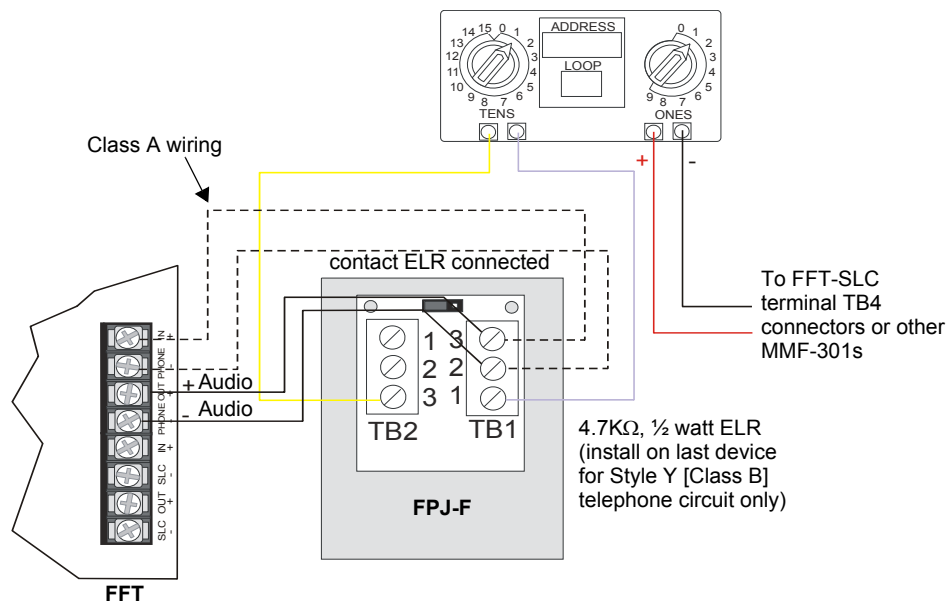

Figure 2.7 FFT to FPJ-F Connection



## 2.7 SLC Device Installation



---

### **WARNING: RISK OF EQUIPMENT DAMAGE AND PERSONAL INJURY**

SEVERAL DIFFERENT SOURCES OF POWER CAN BE CONNECTED TO THIS UNIT. ALWAYS DISCONNECT ALL SOURCES OF POWER BEFORE INSTALLING OR SERVICING.

---

### 2.7.1 List of SLC Devices

The following SLC device can be used with the Fire Fighters Phone. See the device installation instructions for more information (packaged with the device). Refer also to the SLC Wiring Manual #51309 for more information.

Part Number	Model Name/Description	Install Sheet PN
MMF-301	Mini Monitor Module	I56-3654
I300	Fault Isolator Module	I56-1381

### 2.7.2 Maximum Number of Devices

The ECC-FFT supports up to 24 MMF-301 devices on one FFT system.

### 2.7.3 Wiring Requirements for SLC Device

The following information applies to the MMF-301 - Mini Monitor module.

#### **Wiring SLC in Style 4 (Class B) Configuration**

No special wire is required for the ECC-FFT SLC loop. The wire can be untwisted, unshielded, solid or stranded as long as it meets the National Electric Code 760-51 requirements for power limited fire protective signaling cables. Wire distances are computed using copper wire.

Maximum wiring resistance is 40 ohms to the farthest SLC device.

Maximum loop length depends on the wire gauge.

Wire Gauge	Max. Distance
22 AWG	1200 feet
18 AWG	3100 feet
16 AWG	4900 feet
14 AWG	7900 feet
12 AWG	10,000 feet

Figure 2.8 and Figure 2.9 show how length is determined for out and return style wiring.

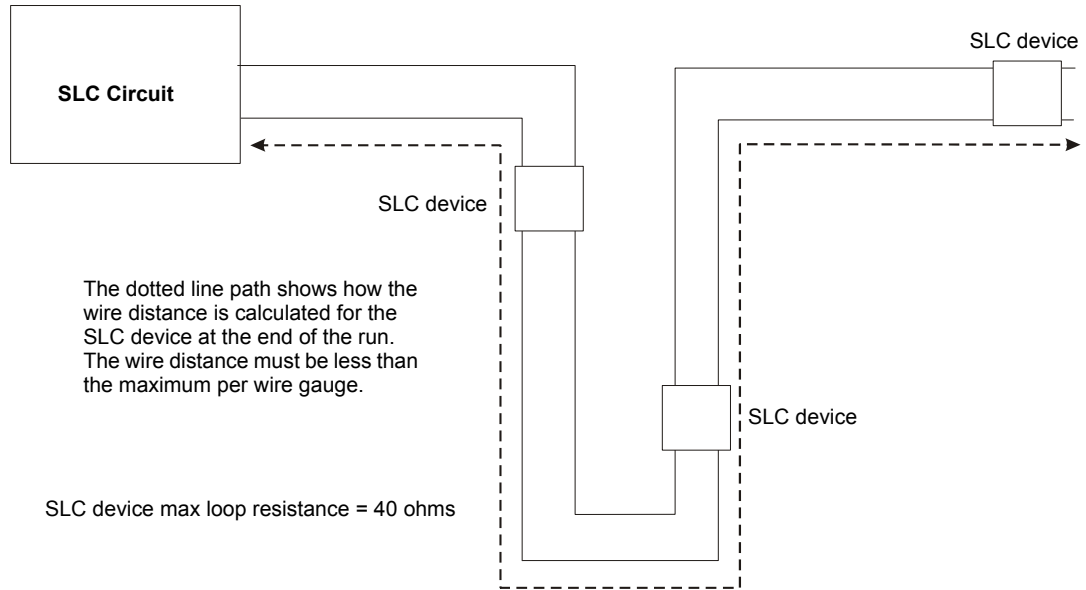

**Figure 2.8 Calculating Wire Run Length**

When using T-taps, the total length of all taps and the main bus must not exceed 40,000 feet. This requirement must be met in addition to the maximum distance requirements for the various wire gauges.

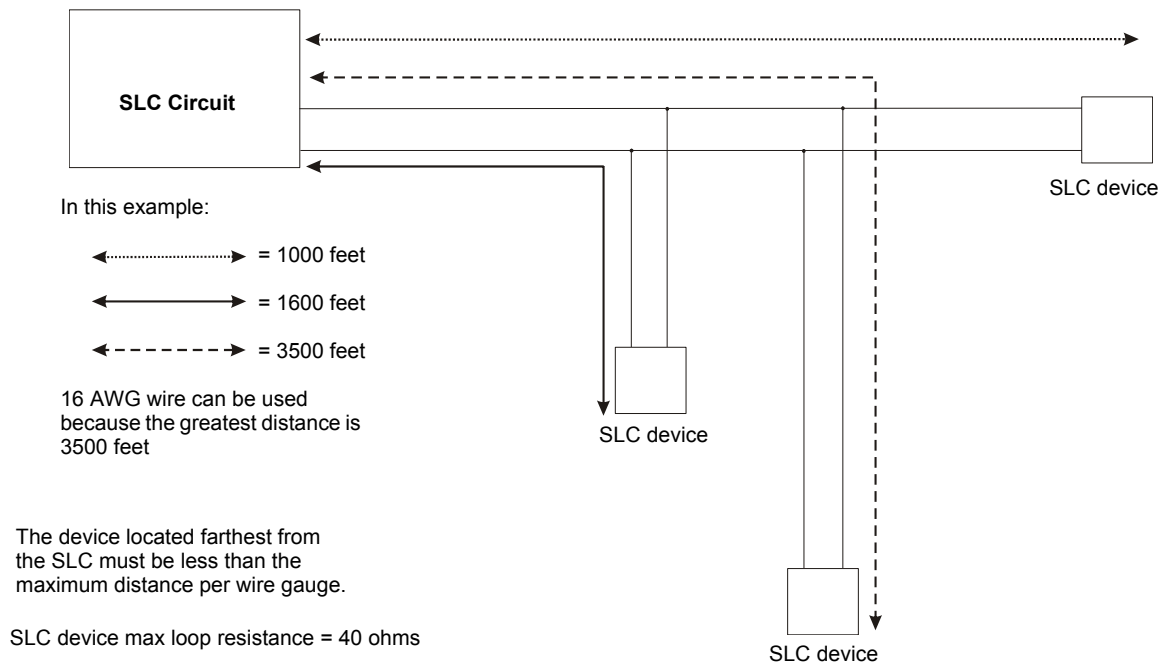

**Figure 2.9 Calculating Wire Run Length for a T-tap**

### Wiring SLC Devices in Style 6 & 7 (Class A) Configuration

Figure 2.10 illustrates how to wire the SLC loop for Style 6 or Style 7 Class A installations.



**NOTE:** Style 6 does not require the use of short circuit isolator devices.

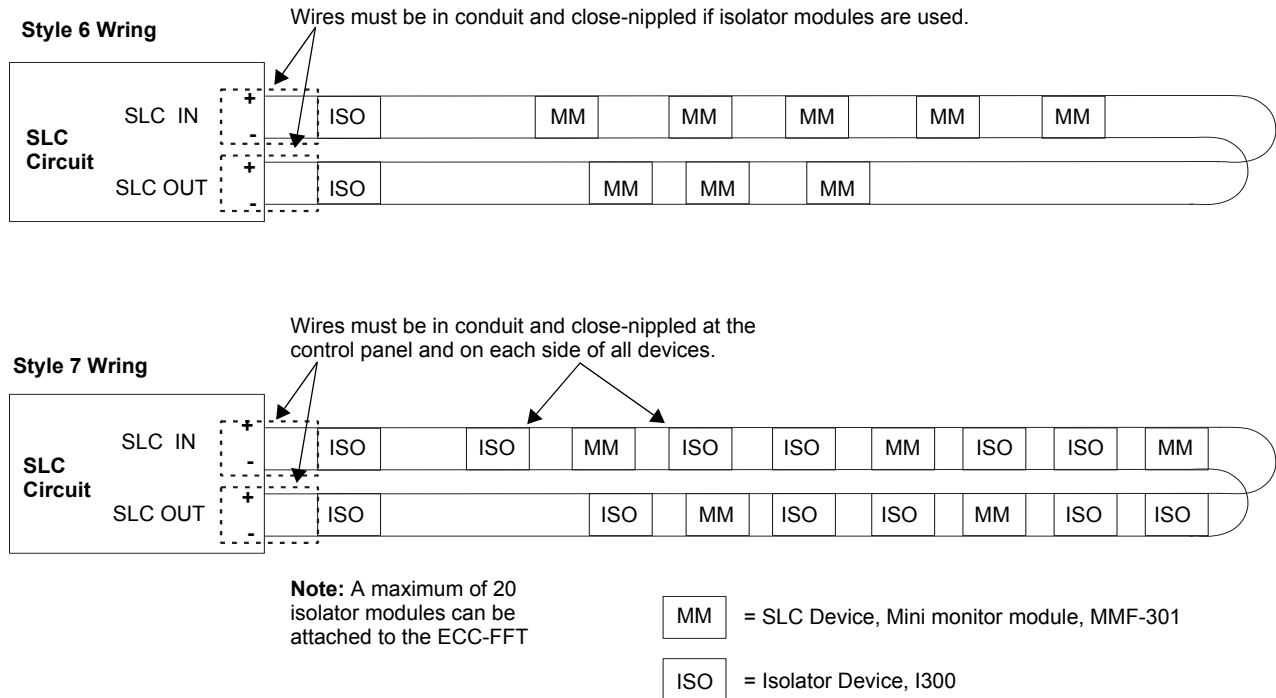

**Figure 2.10 Class A SLC Configuration**



**NOTE:** T-taps are not allowed on Class A SLC loops.



**CAUTION: PROPER SYSTEM SUPERVISION**

FOR PROPER SYSTEM SUPERVISION DO NOT USE LOOPED WIRE UNDER TERMINALS MARKED SLC + AND – OF THE SLC DEVICE CONNECTORS. BREAK WIRE RUNS TO PROVIDE SUPERVISION OF CONNECTIONS.

### 2.7.4 Addressing MMF-301 SLC Devices

All MMF-301 devices are addressed using the two rotary dials that appear on the device board. Use the ONES rotary dial to set the ones place in a one or two digit number, and use the TENS rotary dial to set the tens place in a two digit number.

MMF-301 modules can be assigned any unique address from 1 to 24.

**Example 1:** To select device address 10, turn the *ONES* rotary dial to **0** and the *TENS* rotary dial to **1** as shown below.

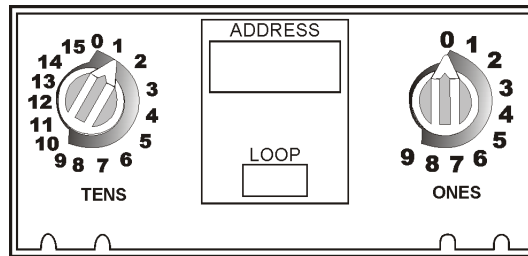

Example 1: MMF-301 SLC Device set to Address 10

**Example 2:** To select device address 42, turn the *ONES* rotary dial to **2** and the *TENS* rotary dial to **4** as show below.

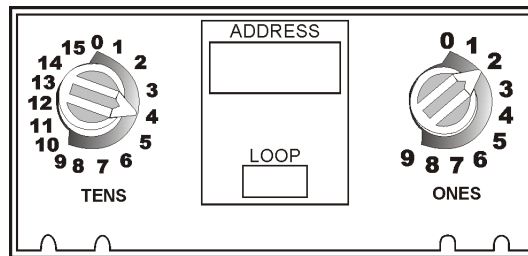

Example 2: MMF-301 SLC Device set to Address 42

## 2.8 Audio Phone Circuit Installation

### 2.8.1 Maximum Number of Devices

The ECC-FFT supports up to 24 zones. Each zone consists of one addressable monitor module (MMF-301) and a minimum of one Fire Fighter Telephone Jack (FPJ-F).

### 2.8.2 Wiring Requirements for the Audio Telephone Circuit

No special wire is required for the Audio Telephone Circuit. The wire can be untwisted, unshielded, twisted or shielded as long as it meets the National Electric code 760-51 requirements for power limited fire protective signaling cables.

54 Ohm maximum impedance - 12 to 18 AWG.

Twisted, shielded wire is recommended for maximum protection against EMI and AFI emissions and susceptibility.

If using shielded cable, attach the shield to Grounding Stud below TB6 of the FFT.



**NOTE:** Do not ground the shield on both ends.

### Single Phone Jack Audio Circuit in Class B Configuration

Figure 2.11 illustrates a single phone jack configuration wiring the audio circuit and SLC for Class B Configuration. Audio circuits must be connected to FFT phone out terminals for all Class B audio configurations.

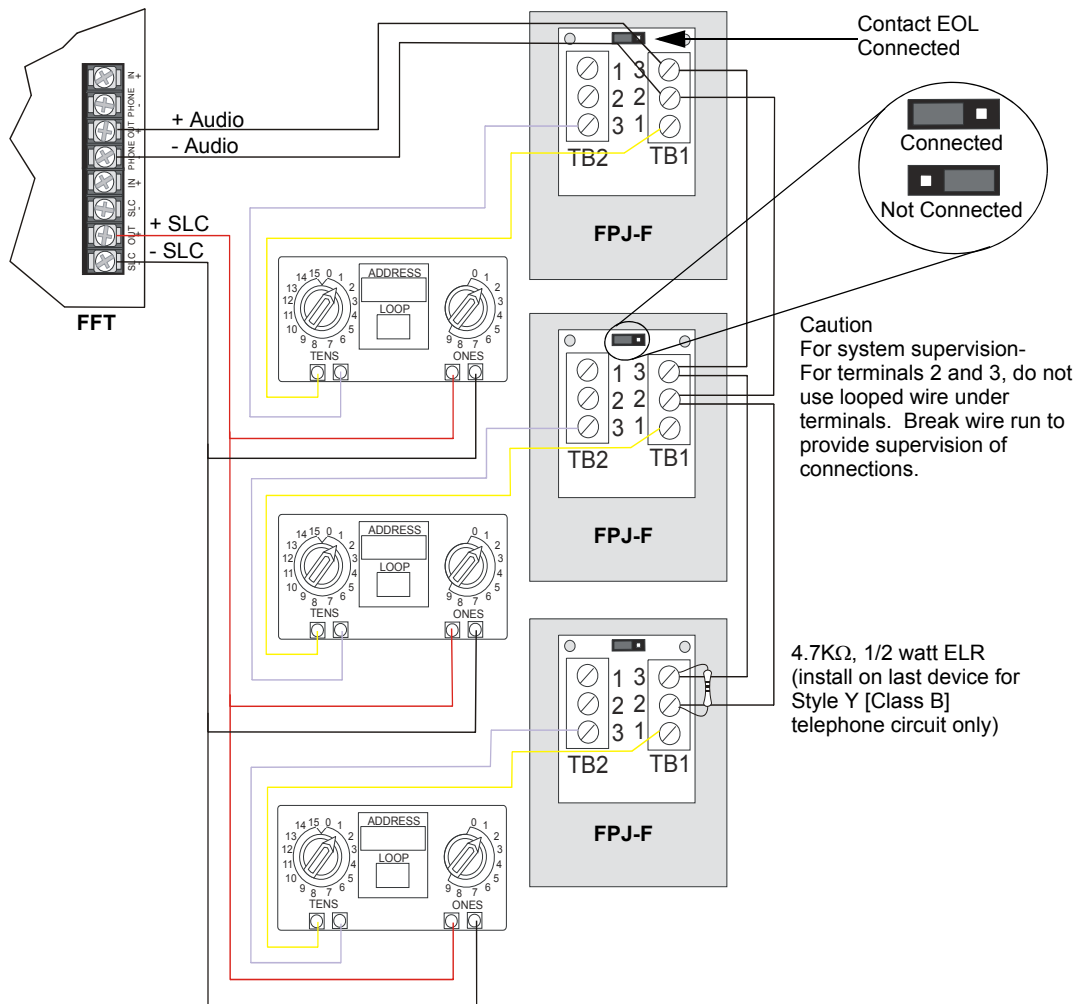

**Figure 2.11 Single Phone Jack Audio Circuit in Class B**

### Single Phone Jack Audio Circuit in Class A Configuration

Figure 2.12 illustrates a phone jack audio circuit (Class A) and SLC for Style 6 & 7 (Class A) configuration.

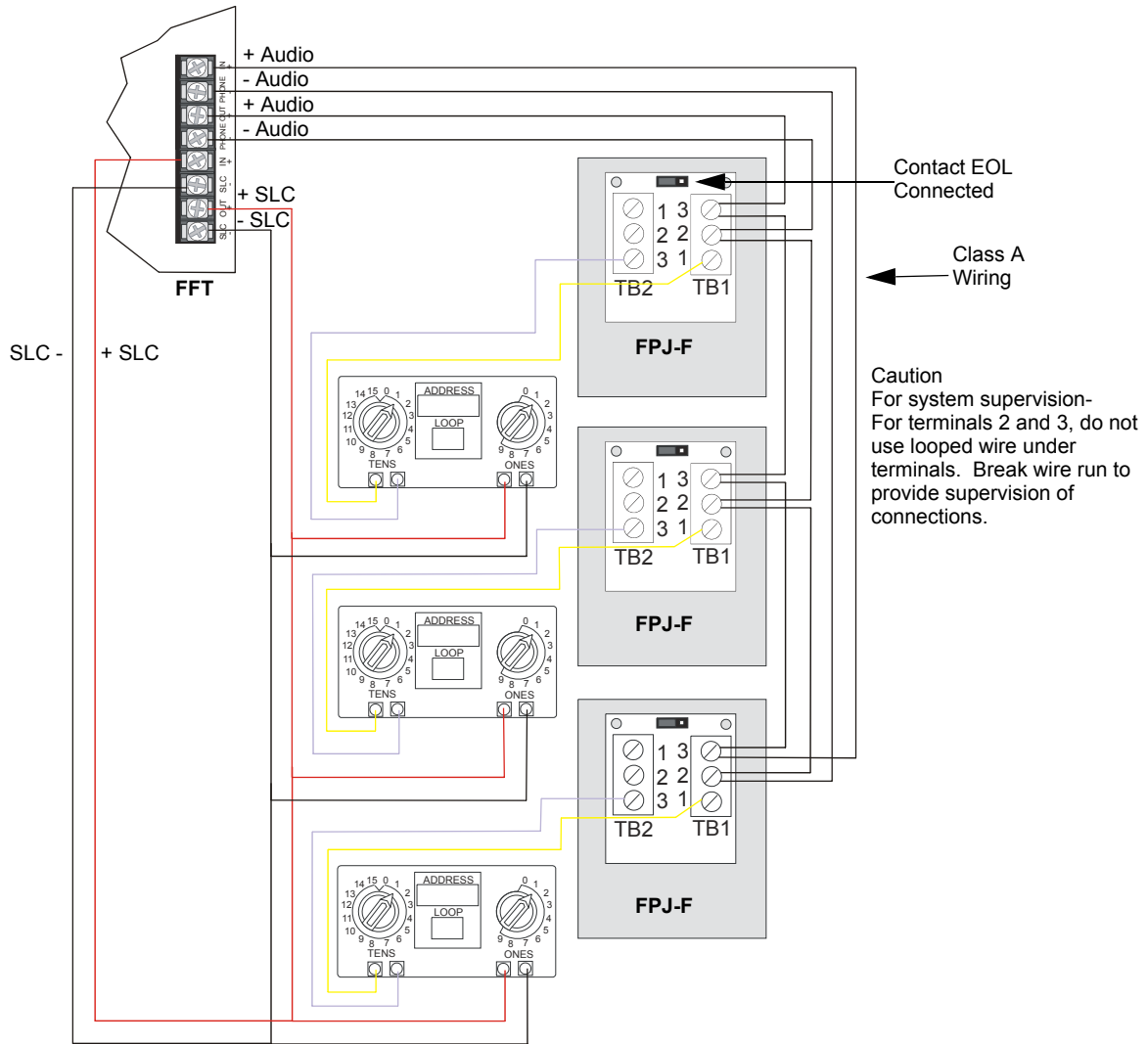

Figure 2.12 Single Phone Jack Audio Circuit in Class A

### Multi-Phone Jack Audio Circuit in Class B Configuration

Figure 2.13 illustrates how to wire the Multi-Phone Jack audio circuit (Class B) and SLC for for Style 4 (Class B) configuration. In the Multi-Phone Jack configuration, the maximum mini-monitor contact wiring resistance between to first and last FPJ-F must be less than 100 ohms.

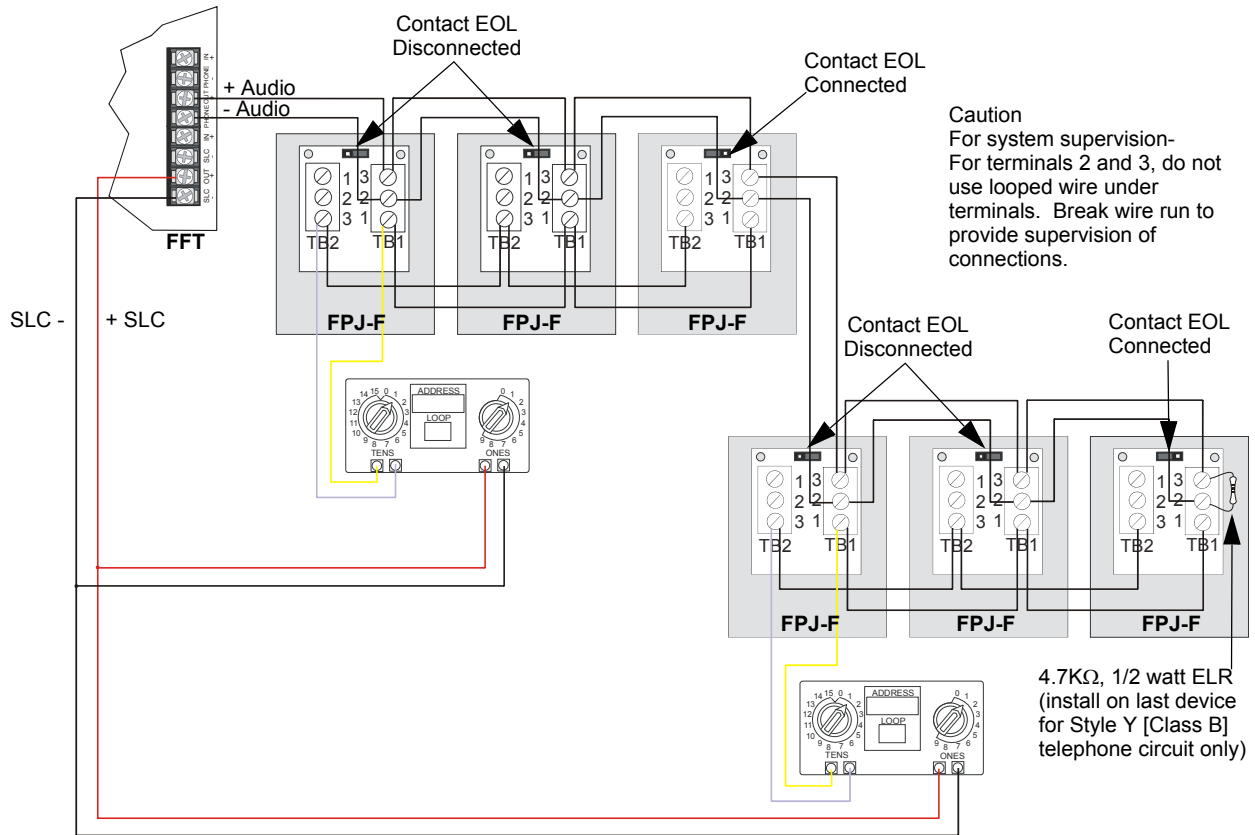

Figure 2.13 Multi-Phone Jack Audio Circuit in Class B

### Multi-Phone Jack Audio Circuit in Class A Configuration

Figure 2.14 illustrates how to wire the Multi-Phone Jack audio circuit (Class A) and SLC for Style 6 & 7 (Class A) configuration. In the Multi-Phone Jack configuration, the maximum Mini-Monitor Contact wiring resistance between to first and last FPJ-F must be less that 100 ohms.

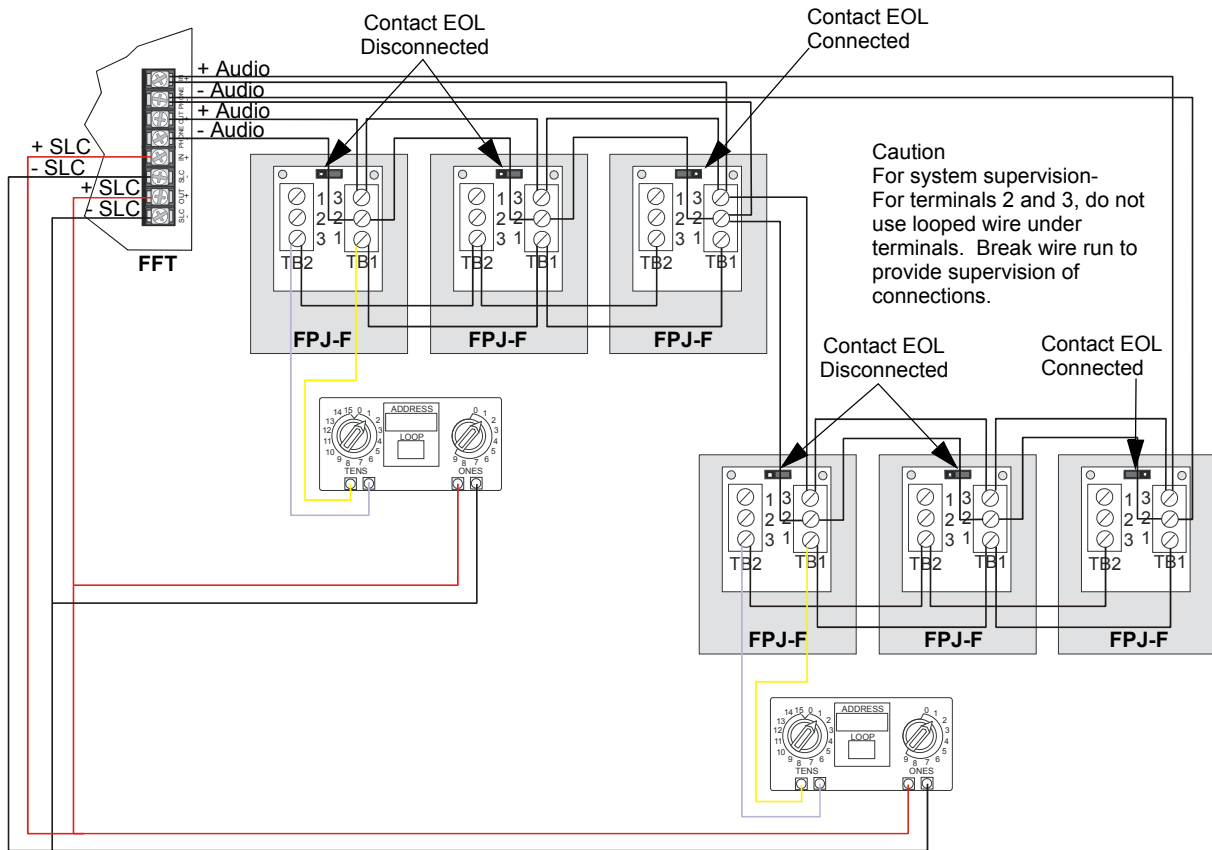

Figure 2.14 Multi-Phone Jack Audio Circuit in Class A



### Telephone Jack Only Audio Circuit

The FFT can also be configured using only the Fire Fighters Phone Jack (FPJ-F). In this configuration, the MMF-301 module is not required for system operation. To configure the FFT for Telephone Jack only, the DIP Switch position 1 must be off (SLC Devices not Installed). See Table 2.1 on page 13.

Audio wiring for this configuration is detailed below. See Figures 2.15 and 2.16.

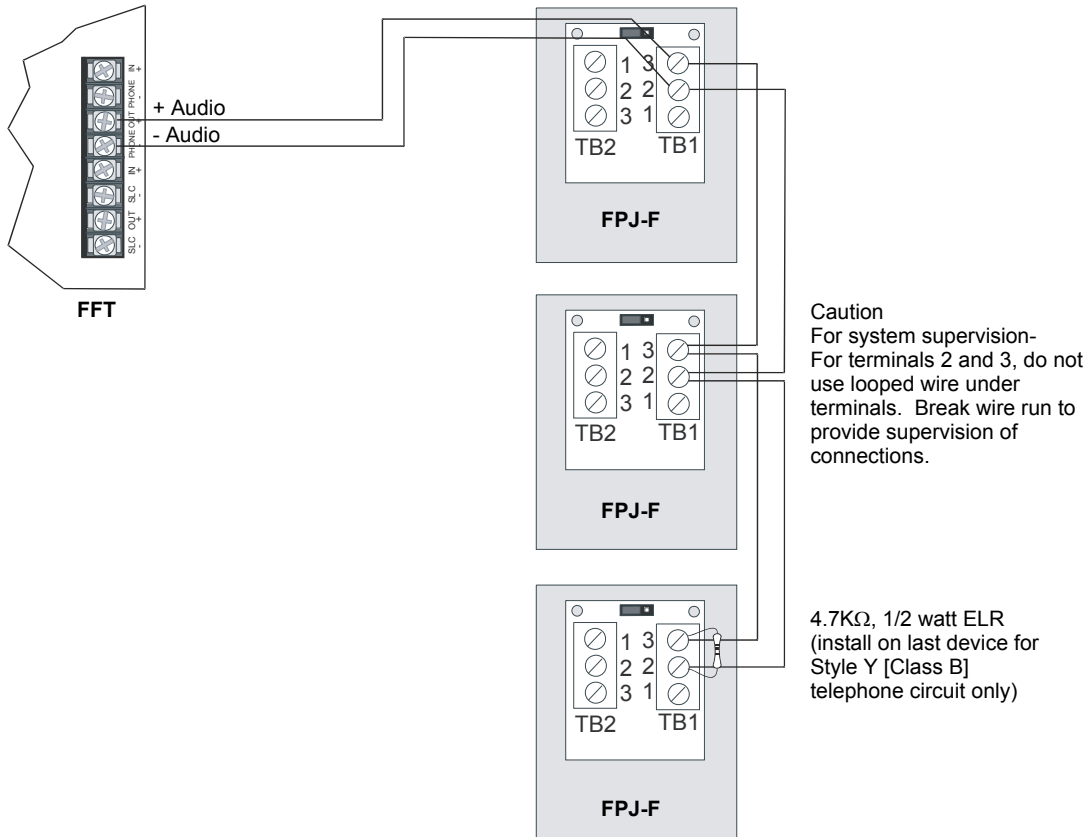
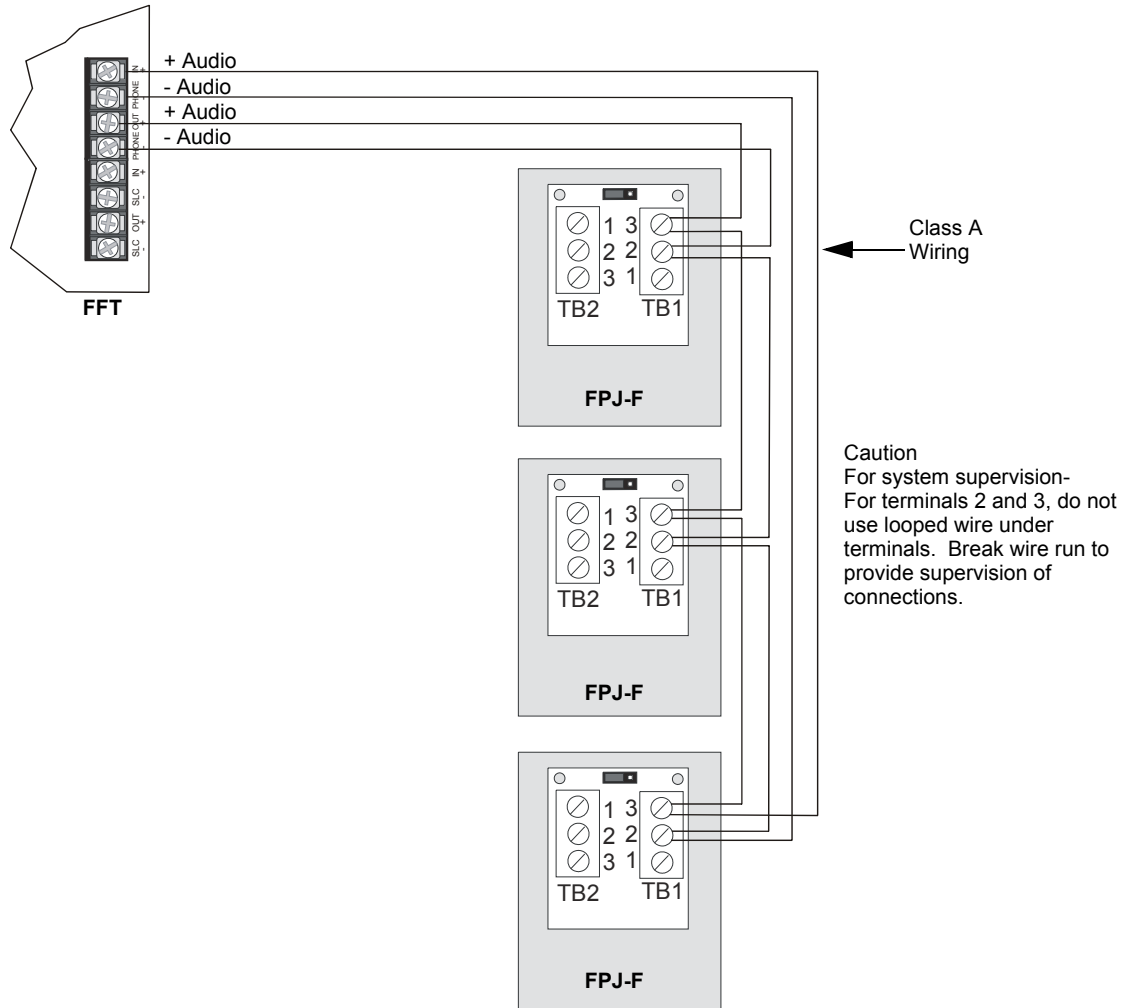

Figure 2.15 Telephone Jack Only Audio Circuit in Class B



**Figure 2.16 Telephone Jack Only Audio Circuit in Class A**

## Section 3: System Operation

The operation of the ECC-FFT Fire Fighter Telephone system allows audio communication from 24 remote connections through remote handsets to a single local handset. Up to 10 remote handsets can be connected and communicating at one time.

### 3.1 Push-button Operations

#### **Autoprogram (on inside of FFT dress panel)**

The Autoprogram key will cause the FFT to search the SLC loop for devices. The Active LED (green) will then blink for each zone where a device was found. Press and hold the Autoprogram button for 2 seconds in order to initiate this feature.

#### **Accept (on inside of FFT dress panel)**

The Accept button is used after Autoprogram. It will save the current SLC device configuration and re-initialize the FFT. If the Accept button is not pressed within one minute after the Autoprogram is complete, its configuration will be discarded and the FFT will be restarted.

#### **Answer Call**

When a remote handset is connected to one of the FPJ-F phone jacks, the Answer Call LED will blink and the FFT's piezo will sound. Pressing the Answer Call button will connect the local handset to the phone circuit, turn the Answer Call LED on steady, and silence the piezo. Communication between the local and remote handset is now possible. Up to ten remote handsets can be connected to the phone circuit simultaneously. After the initial remote handset, the connection of additional handsets does not cause the piezo to sound or the Answer Call LED to blink.

#### **Trouble Silence**

The Trouble Silence button is used to silence a system type trouble that has occurred in the FFT system. Once pressed, the piezo will silence.

### 3.2 LED Operations

#### **Power Status LED (on Inside of FFT dress panel)**

The status LED is located on the right side of the FFT board. On power-up, the power status LED will blink at a 50% on/off rate until FFT initialization is complete (which takes approximately 20 seconds). Once initialization is complete, the status LED will blink at a 10% on and 90% off rate.

No key input will be valid until the FFT completes its initialization.

#### **Answer Call**

When a remote handset connects to the audio channel, the Answer Call LED will blink and the piezo will sound. The operator at the FFT then picks up the local handset and presses the Answer button which causes the Answer Call LED to remain on steady and the piezo goes silent. Communication between the local and remote handset is now established. Additional remote handsets can be attached to the audio connection without any intervention at the FFT. Once the last remote handset has disconnected from the FFT, the answer LED will turn off and the system will return to normal.

#### **Power**

The Power LED indicates that 24 VDC is connected to the FFT.

#### **Local Trouble**

The local handset trouble LED will activate and blink when there is a problem with the local handset.

### Remote Trouble

The remote handset trouble LED will activate and blink when there is a problem with the phone circuit.

### General Trouble

The General Trouble LED will blink active when system troubles are detected. When the Trouble Silence button is pressed, the General Trouble LED will light steady. Once all system troubles have been restored, the General Trouble LED will turn off.

### Status LEDs (on Inside of FFT dress panel)

- LED 1 - SLC Supervision
- LED 2 - SLC Extra Point Detected
- LED 3 - Future Use
- LED 4 - Audio Circuit Supervision



**NOTE:** Troubles that will turn these LEDs on are: SLC shorted, SLC Class A Open Trouble, and Wrong Device Type.

### Zone Active

Each zone has an Active LED (see Figure 3.1). The zone's Active LED will illuminate when a remote handset is plugged into that zone. The LED will turn off when the handset is removed from the zone.

### Zone Trouble

Each zone has a Trouble LED. The zone's Trouble LED will blink when specific SLC issues occur such as a missing device or double address. Pressing the Trouble Silence Key will cause the zone trouble LED to turn on steady. Once the zone trouble is corrected, the LED will turn off.

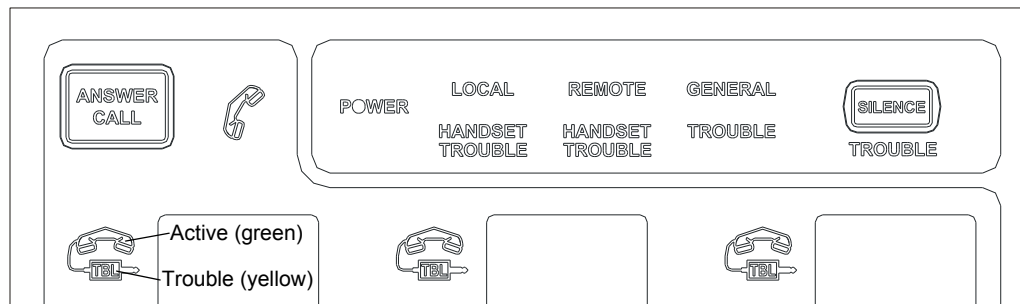

**Figure 3.1 LED Operations**

## 3.3 Autoprogram Operation

The Autoprogram feature will attempt to locate all SLC Mini-Monitor devices installed in the system, indicate all devices found on the FFT and allow the user to accept the configuration, repeat the Autoprogram, or allow the configuration to be discarded.

1. To perform the FFT Autoprogram press and hold the Autoprogram button for 2 seconds.
2. The FFT will search for installed SLC devices and activate the Active LEDs of all zone/point addresses found.
3. When the Autoprogram is complete, the first four status LEDs will blink. The user can now press the ACCEPT key causing the FFT to save the configuration and restart.
4. The user presses the Autoprogram key again to repeat the SLC search process.
5. If the user does not press the Accept key within one minute after the Autoprogram is complete, its configuration will be discarded and the FFT will be restarted.

# Slide-in Labels

Carefully cut along the outside of each label. Identify the keypad buttons as desired and slide the labels in. The labels slide upwards through the slits in the bottom of the keypad, covering the white spaces.

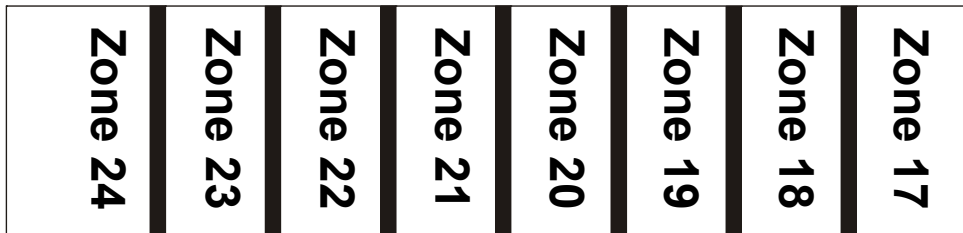
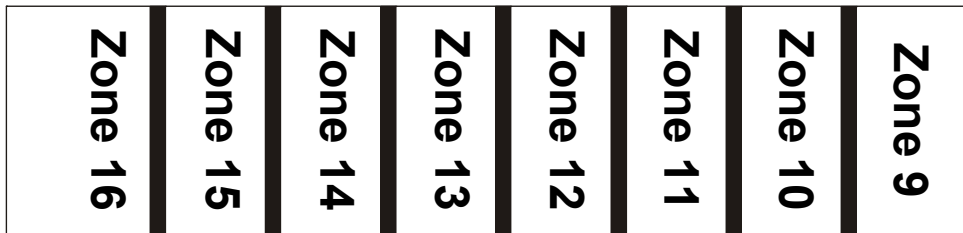
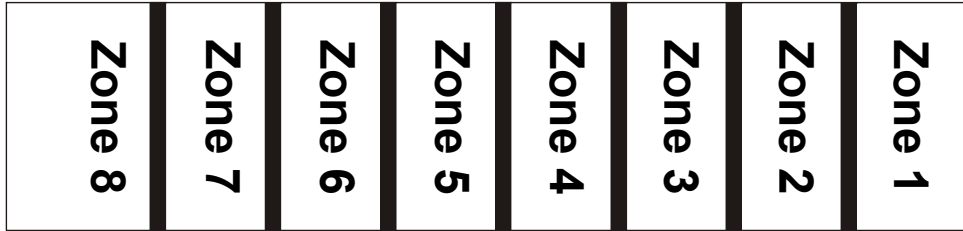



## Manufacturer Warranties and Limitation of Liability

**Manufacturer Warranties.** Subject to the limitations set forth herein, Manufacturer warrants that the Products manufactured by it in its Northford, Connecticut facility and sold by it to its authorized Distributors shall be free, under normal use and service, from defects in material and workmanship for a period of thirty six months (36) months from the date of manufacture (effective Jan. 1, 2009). The Products manufactured and sold by Manufacturer are date stamped at the time of production. Manufacturer does not warrant Products that are not manufactured by it in its Northford, Connecticut facility but assigns to its Distributor, to the extent possible, any warranty offered by the manufacturer of such product. This warranty shall be void if a Product is altered, serviced or repaired by anyone other than Manufacturer or its authorized Distributors. This warranty shall also be void if there is a failure to maintain the Products and the systems in which they operate in proper working conditions.

MANUFACTURER MAKES NO FURTHER WARRANTIES, AND DISCLAIMS ANY AND ALL OTHER WARRANTIES, EITHER EXPRESSED OR IMPLIED, WITH RESPECT TO THE PRODUCTS, TRADEMARKS, PROGRAMS AND SERVICES RENDERED BY MANUFACTURER INCLUDING WITHOUT LIMITATION, INFRINGEMENT, TITLE, MERCHANTABILITY, OR FITNESS FOR ANY PARTICULAR PURPOSE. MANUFACTURER SHALL NOT BE LIABLE FOR ANY PERSONAL INJURY OR DEATH WHICH MAY ARISE IN THE COURSE OF, OR AS A RESULT OF, PERSONAL, COMMERCIAL OR INDUSTRIAL USES OF ITS PRODUCTS.

This document constitutes the only warranty made by Manufacturer with respect to its products and replaces all previous warranties and is the only warranty made by Manufacturer. No increase or alteration, written or verbal, of the obligation of this warranty is authorized. Manufacturer does not represent that its products will prevent any loss by fire or otherwise.

**Warranty Claims.** Manufacturer shall replace or repair, at Manufacturer's discretion, each part returned by its authorized Distributor and acknowledged by Manufacturer to be defective, provided that such part shall have been returned to Manufacturer with all charges prepaid and the authorized Distributor has completed Manufacturer's Return Material Authorization form. The replacement part shall come from Manufacturer's stock and may be new or refurbished. THE FOREGOING IS DISTRIBUTOR'S SOLE AND EXCLUSIVE REMEDY IN THE EVENT OF A WARRANTY CLAIM.

Warn-HL-08-2009.fm



---

World Headquarters  
1 Firelite Place  
Northford, CT 06472-1653 USA  
203-484-7161  
fax 203-484-7118

[www.firelite.com](http://www.firelite.com)

**ISO 9001**  
**CERTIFIED**  
ENGINEERING & MANUFACTURING  
QUALITY SYSTEMS