

The TC-4F

Time Control Module

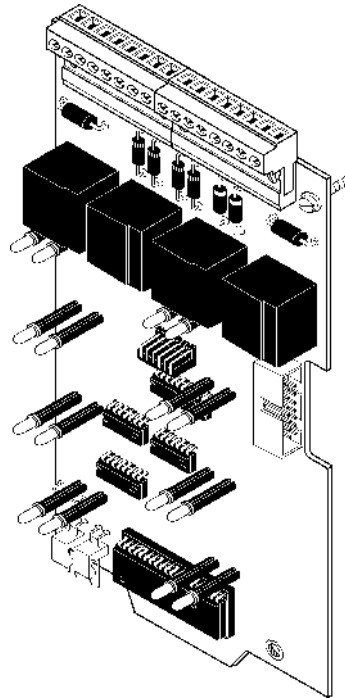

For the Sensican 2000 Fire Alarm Control Panel

Table of Contents

| | Page |
|--|------------------------------|
| Section One: General Information | 4 |
| Section Two: Inventory | 5 |
| Section Three: Installation | 7 |
| Mounting Optional Expanders | 7 |
| Installation | 8 |
| Harness Connections | 8 |
| Power Consideration for the TC-4F | 9 |
| Section Four: Terminal Wiring | 10 |
| Multi-Hazard Release | 10 |
| Dual-Code Alert/Evacuation | 11 |
| Wiring the CRE-4F | 12 |
| Section Five: Programming the TC-4F | 13 |
| Section Six: Operating the TC-4F | 15 |
| Multi-Hazard Release | 15 |
| Dual-Code Alert/Evacuation | 16 |
| Slide-In Labels for the TC-4F | <i>Inside back cover</i> |

Section One: General Information

Introduction

The TC-4F is a time control module for use with the Sensiscan 2000 fire alarm control panel. It can be operated in one of two modes - Multi-Hazard Release or Two-Stage Alert/Evacuation. Programming of the TC-4F is accomplished during programming of the respective fire alarm control panel.

Multi-Hazard Release

When programmed for Multi-Hazard Release, the TC-4F provides four independently-operated releasing circuits. The functions of the module can be expanded with the use of an ICE-4F Indicating Circuit Expander or a CRE-4F Control Relay Expander.

Key Multi-Hazard Release features:

- Cross or Single Zone Release capability
- Optional Delay Timer
- Optional Soak Timer
- Manual Release
- Warning Bell Circuits (requires installation of an ICE-4F)

Two-Stage Alert/Evacuation

When programmed for Two-Stage Alert/Evacuation, the TC-4F provides four independent Notification Appliance Circuits. Each of these circuits has an alert select and evacuation select function. If alert has been selected, the particular notification circuit will pulse at 20 pulses per minute (PPM). If evacuation has been selected, the notification circuit will pulse at 120 PPM. The functions of the module can be expanded by using an ICE-4F or CRE-4F.

Key Two-Stage Alert/Evacuation features:

- Alert Timer
- Alert Hold
- Evacuation Relays (requires installation of a CRE-4F)
- Separate Evacuation Outputs (requires installation of an ICE-4F)

About this Manual

This document contains information specific to the TC-4F. Before installing the TC-4F, you should be familiar with the installation manual for the respective fire alarm control panel:

The Sensiscan 2000 Installation, Operation, and Programming Manual, Document 15017.

See the System Marking Label on the cabinet door for the latest revision of that system's manual.

Refer to the Device Compatibility Document, 15384, for a listing of compatible releasing devices and Notification Appliances.

Power Calculations

Standby Current: 0.007 amps Alarm Current: 0.072 amps

Refer to the respective fire alarm control panel manual for calculation of primary and secondary power requirements for the TC-4F.

Section Two: Inventory

The TC-4F Time Control Module features removable terminal blocks that ease installation and servicing. Provided with the module are two harnesses for connection to the source of power. Also included are four End-of-Line resistors, four 4.7K Dummy Load resistors, and four 1K Dummy Load resistors.

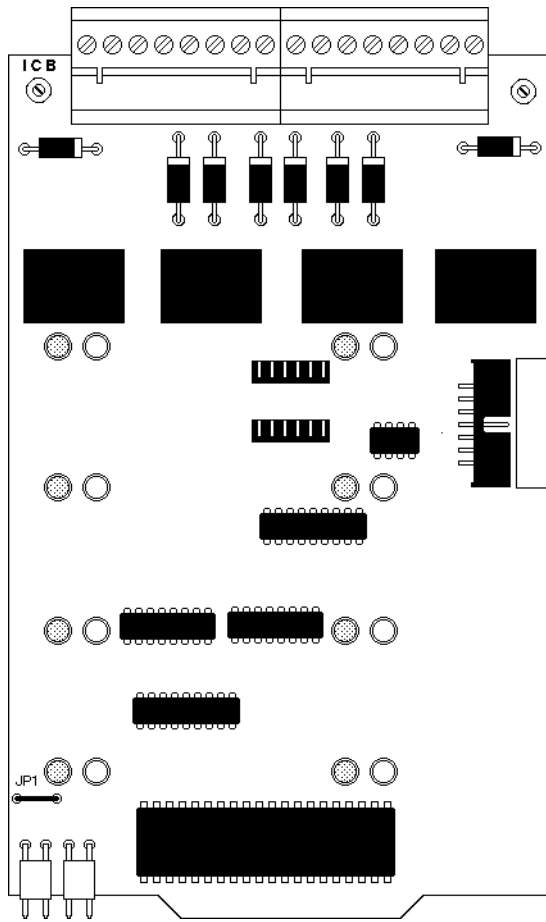

The TC-4F



**4.7 K 1/2-watt
End of Line
Resistors (71252)**



**4.7 K 1/2-watt
Dummy Load
Resistor (71245)**



**1K 1-watt
Dummy Load
Resistor (27040)**



Power Harness (71091)



Power Harness (71093)

Optional Equipment for the TC-4F Time Control Module

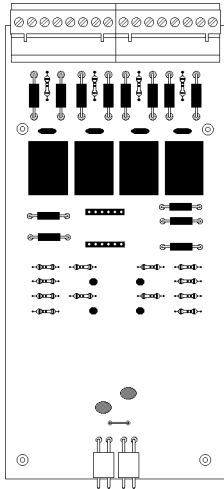

ICE-4F Indicating Circuit Expander

The ICE-4F provides four warning bell circuits for the TC-4F when operated in Multi-Hazard Release mode or four evacuation outputs when the TC-4F is operated in Two-Stage Alert/Evacuation mode. The expander plugs into the back of the TC-4F. An Auxiliary Bell Power Harness (below) is provided with each expander.



CRE-4F Control Relay Expander

The CRE-4F provides four evacuation relays for the TC-4F when operated in Two-Stage Alert/Evacuation mode. The expander plugs into the back of the TC-4F.

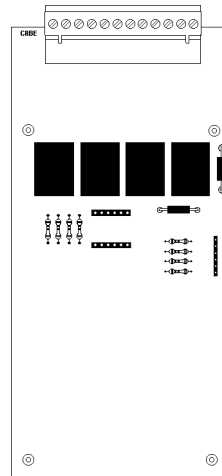

Section Three: Installation

Installation Outline

- 1) If an optional ICE-4F or CRE-4F is to be used, mount the expander board to the TC-4F as illustrated in Figure 3-1.
- 2) Mount the TC-4F assembly into the CHS-4F Chassis as illustrated in Figure 3-2.
- 3) Connect the 1st Row or Expander Row Ribbon Cable from the system's CPU module to the TC-4F as illustrated in Figure 3-3. This figure also illustrates connection of notification appliance power or releasing solenoid power to the TC-4F, using power harnesses.
- 4) Field wire TC-4F circuits to the removable terminal blocks as illustrated in the figures of Section Four.

** The TC-4F is now ready to be programmed. Refer to Section Five. **

Figure 3-1: Mounting an Optional ICE-4F or CRE-4F Expander

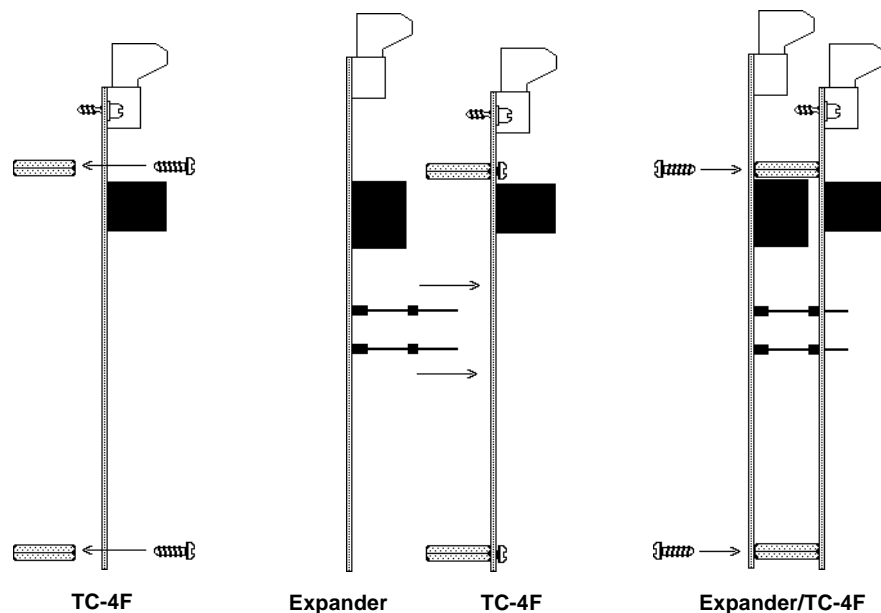

Step 1:
Attach four standoffs to the TC-4F using the four screws provided.

Step 2:
Insert the pins on the ICE-4F or CRE-4F expander board into the connector on the TC-4F and press the two boards together, ensuring that the pins are properly aligned.

Step 3:
Secure the TC-4F/Expander assembly with four screws into the standoffs.

Figure 3-2: Installation

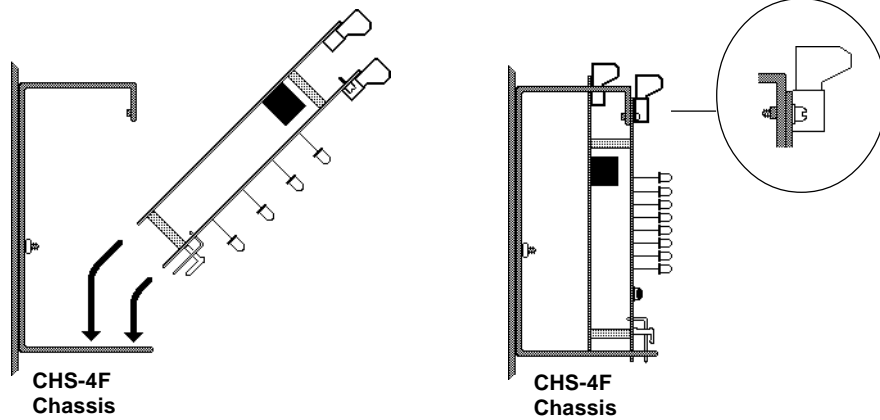

Step 1:
Angle the TC-4F assembly into the CHS-4F Chassis so that the upper board edge slips into the slot on the bottom rail of the chassis.

Step 2:
Push the upper end of the TC-4F assembly into the chassis and secure with the module's two captive screws. Straighten LEDs so that they extend from the TC-4F at a 90-degree angle.

Figure 3-3: Harness Connections

1) If power for the TC-4F (or the ICE-4F) is to come from an MPS, connect Power Harness 71093 from J5 on the TC-4F to the power supply. If the AVPS-24F is to be used, connect Power Harness 71091 from J5 to P3 on the AVPS-24F. If the TC-4F is to share power with another module, connect Power Harness 71091 from J6 on that module to J5 on the TC-4F. For various supply configurations for the TC-4F, see the next page.

2) Connect the 1st Row Ribbon or Expander Row Ribbon Cable from the CPU module to the TC-4F as illustrated.

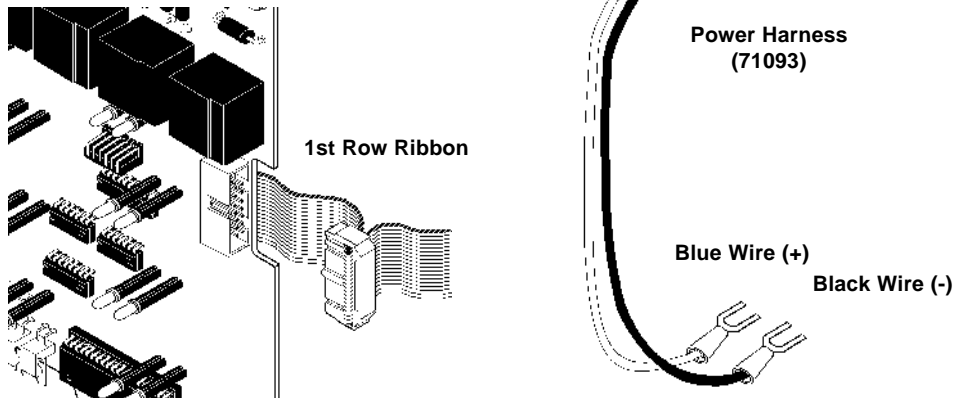

Powering the TC-4F for Multi-Hazard Release

When used for Multi-Hazard Releasing service, the TC-4F must be supplied with regulated 24 VDC power for compatibility with listed 24V release solenoids. **Note:** The illustration below assumes that no other power is drawn from the regulated output of the MPS. If this is not the case, reduce the maximum current that can be supplied to the TC-4F appropriately.

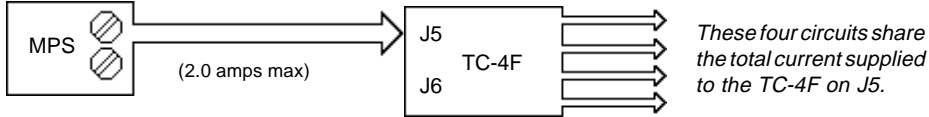

MPS-24BF: Connect to TB2 Terminals 3 (+) and 4 (-). **CAUTION:** The +24 VDC provided on TB2 Terminal 3 is power-limited only when used with the minus return on TB2 Terminal 4. Do not use the minus return on TB2 Terminal 2 with the +24 VDC power on TB2 Terminal 3.

Powering the TC-4F for Dual-Code Alert/Evacuation

When used for Dual-Code Alert/Evacuation service, the TC-4F/ICE-4F does not require regulated 24 VDC power. This power can be supplied by notification appliance power from the MPS-24AF, MPS-24BF (and MPS-24BRBF), the AVPS-24F or any UL Listed power-limited power supply. Refer to the Device Compatibility Document for a list of compatible, UL listed Notification Appliances. **Note:** The illustrations below assume that no other notification appliance power is drawn from MPS or AVPS-24F. If this is not the case, reduce the maximum current that can be supplied to the TC-4F/ICE-4F appropriately.

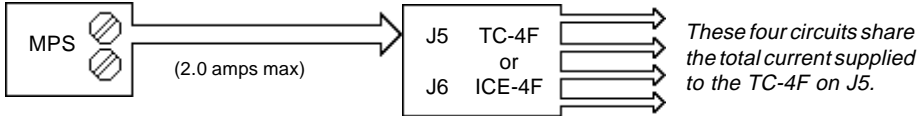

MPS-24BF: Connect to TB2 Terminals 3 (+) and 4 (-). **CAUTION:** The +24 VDC provided on TB2 Terminal 3 is power-limited only when used with the minus return on TB2 Terminal 4. Do not use the minus return on TB2 Terminal 2 with the +24 VDC power on TB2 Terminal 3.

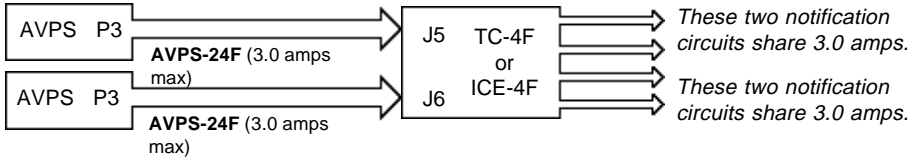
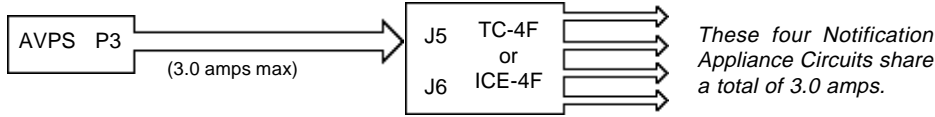

IMPORTANT:
Cut jumper JP1 when supplying the TC-4F with two different power sources.

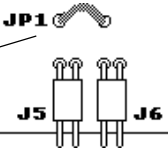

Section Four: Terminal Wiring

Multi Hazard Release

Release Circuits

The TC-4F has four supervised independent release circuits. Unused circuits must be terminated with a 1K, 1-watt dummy load resistor. These circuits are used to power UL listed 24VDC releasing solenoids. The addition of an ICE-4F provides up to four Warning Bell Circuits (use only the UL-listed Notification Appliances listed in the Device Compatibility Document). *You cannot mix releasing and Notification Circuits on a TC-4F within the same fire alarm control panel system.*

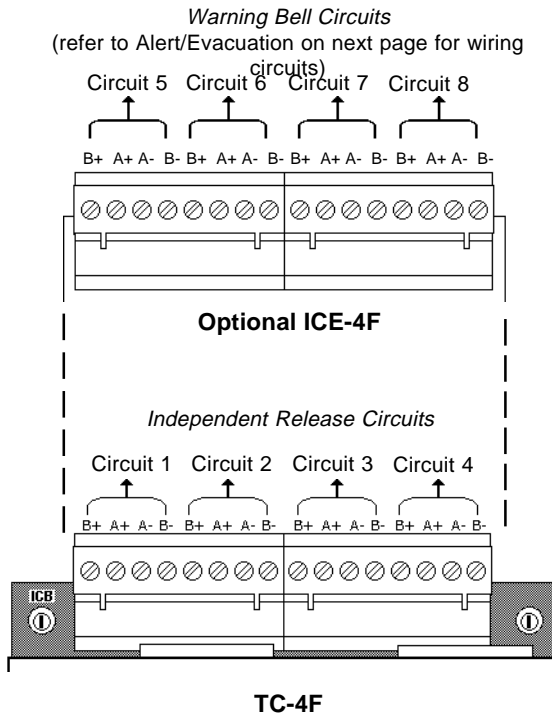

Field Wiring Notes:

- 1) Warning Bell and Release Circuits are nonpower-limited.
- 2) Wire all devices according to packaged instructions.
- 3) Size wire for a maximum voltage drop of 2.0 VDC.
- 4) The ICE-4F provides an independent warning bell circuit for each one of the release circuits. Bell circuit activation occurs when Enables A and B of the corresponding release circuit are activated. A bell circuit will not be delayed even if the delay timer has been programmed.
- 5) Maximum Current per circuit is 3.0 amps, subject to the limitations of the supply providing notification appliance power. Refer to *Powering the TC-4F* for supply configurations.

UL listed 24VDC releasing solenoid

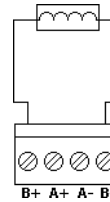

NFPA Style Y Release Circuit

UL listed 24VDC releasing solenoid

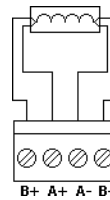

Four-Wire Style Y Release Circuit

1K 1-watt Dummy Load Resistor (27040)

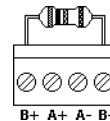

Unused Circuits

Dual-Code Alert/Evacuation

Notification Circuits.

The TC-4F has four notification circuits that can be wired NFPA Style Y or Z. These circuits are supervised and power limited. Use only those 24 VDC polarized UL listed notification appliances that are listed in the Device Compatibility Document. Unused notification circuits must be terminated with 4.7K dummy load resistors. Up to four evacuation-only notification circuits can be added by using an ICE-4F. *You cannot mix releasing and Notification Circuits on a TC-4F within the same fire alarm control panel system.*

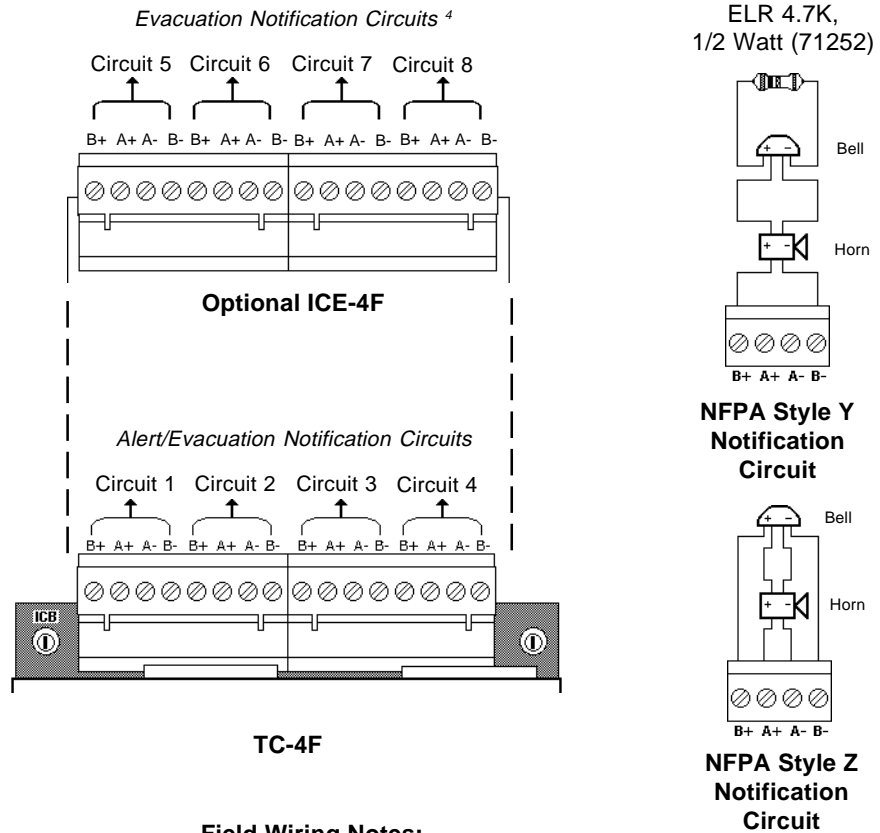

Field Wiring Notes:

- 1) Notification Appliance Circuits are power-limited and may be connected to limited energy cable.
- 2) Wire Notification Appliances according to packaged instructions.
- 3) Size wire for a maximum voltage drop of 2.0 VDC.
- 4) The ICE-4F provides an independent notification circuit for each alert evacuation circuit. Notification circuit activation occurs when the corresponding circuit on the TC-4F goes into the evacuation state. The circuit on the ICE-4F does not pulse but stays on steady.
- 5) Maximum Current per circuit is 3.0 amps, subject to the limitations of the supply providing Notification Appliance power. Refer to *Powering the TC-4F* for supply configurations.

4.7k 1/2-watt
Dummy Load
Resistor (71245)

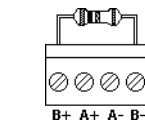

Unused Circuits

Field Wiring the CRE-4F

Multi Hazard Release

Relay Activation

The CRE-4F Control Relay Expander provides one Form-C contact for each release circuit. The relay will activate when enable A and B are both activated for the corresponding release circuit. They will not be delayed even if the delay timer has been programmed.

Dual-Code Alert/Evacuation

Relay Activation

The CRE-4F Control Relay Expander provides one Form-C contact for each Notification Appliance Circuit. The relay will activate when the notification circuit goes into evacuation mode. It will not activate when the circuit is in alert mode.

If using a mix of power-limited and nonpower-limited circuits, maintain 0.25" spacing between power-limited and nonpower-limited wires and enter/exit enclosure through different knockouts.

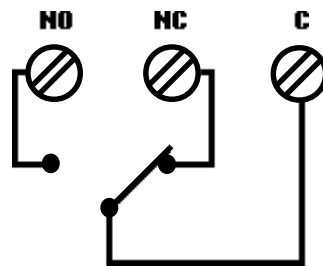
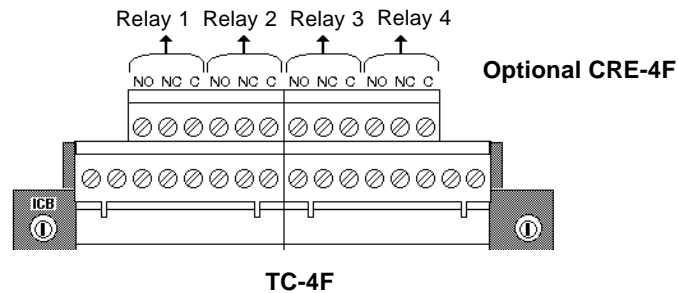

Typical Relay in Standby Position

The contacts are rated for 5 amps @ 120VAC or 28VDC (resistive).

Section Five: Programming the TC-4F

This section contains programming information specific to the TC-4F. For general information on programming, refer to the manual for the respective fire alarm control panel.

Reconfigure

The control panel must be reconfigured any time a new module has been installed. After entering the reconfiguration password, all green LEDs on the TC-4F should light if the module has been installed correctly. Press *ESCAPE* to confirm system configuration.

Programming

The following parameters need to be programmed for a TC-4F to operate properly.

Multi Hazard Release

Silenceable Outputs

Select all TC-4F outputs as nonsilenceable.

When the Silenceable LED is flashing, turn off all LEDs on TC-4F.

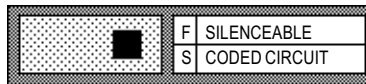

Dual-Code Alert/Evacuation

Silenceable Outputs

If any circuit is to be silenceable, select both alert and evacuation for silenceable.

When the Silenceable LED is flashing, turn the green LED on for both alert and evacuation for all circuits that are to be silenceable.

Delay Timer

If any circuit is to have a delay timer, select its Enable A as a coded circuit.

When the Coded Circuit LED is lit, turn the green Enable A LED on for any circuit that requires a delay timer.

Soak Timer

If any circuit is to have a soak timer, select its Enable B as a coded circuit.

When the Coded Circuit LED is lit, turn the green Enable B LED on for any circuit that requires a soak timer.

Coded Circuits

Select all alert and evacuation inputs for coded circuits.

When the Coded Circuit LED is on steady, turn on all green LEDs on the TC-4F.

Multi Hazard Release

Code Type

March Time Code must be selected for Code Type.

When the Code Type LED is flashing, set the yellow LED on Notification Circuit 1 for March Time Code.

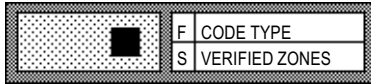

I/O Map

Each of the enables can be mapped to any initiating zones. If you desire cross zone operation, Enables A and B should be mapped to different initiating circuits. If cross zoning is not desired, then map initiating circuits to both A and B.

When the I/O Map led is on, each of the initiating circuits can be mapped to outputs. The green enable LEDs on the TC-4F, should be turned on for each of the initiating circuits that are mapped to it.

Single Zone Release

When mapping a release circuit for single zone release, map the initiating circuit to both Enables A and B of that releasing circuit.

Note: A releasing circuit can be mapped to more than one initiating circuit.

Cross Zone Release

When mapping a release circuit for cross zone release, map Enables A and B to different initiating circuits.

Note: Enable A or B can be mapped to more than one initiating circuit.

Dual-Code Alert/Evacuation

Code Type

Temporal Code must be selected for Code Type.

When the Code Type LED is flashing, set the green LED on Notification Circuit 1 for Temporal Code.

I/O Map

The evacuation and alert inputs can be mapped to any initiating circuit.

When the I/O Map LED is on, initiating circuits can be mapped for alert and evacuation.

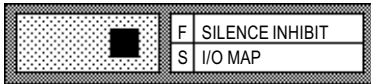

To map an initiating circuit for alert, turn the green alert LED on when the red LED on the initiating circuit is on.

To map an initiating circuit for evacuation, turn the green evacuation LED on when the red LED on the initiating circuit is on.

Section Six: Operating the TC-4F

Multi-Hazard Release Operation

Cross-Zoning

Each of the release circuits has two enable inputs. Both enables must be activated before the release sequence will begin. If cross-zoning is desired, separate initiating circuits should be mapped to A and B. If cross-zoning is not desired, initiating circuits must be mapped to both A and B inputs (see Programming the TC-4F). The green LED will turn on for an enable that has been activated.

Delay Timer

An optional delay timer may be programmed per circuit. This timer will delay the activation of the release circuit by 15 seconds (nonadjustable). The delay timer will begin after both enables are received. When this timer is activated, the green LED for Enable A will flash.

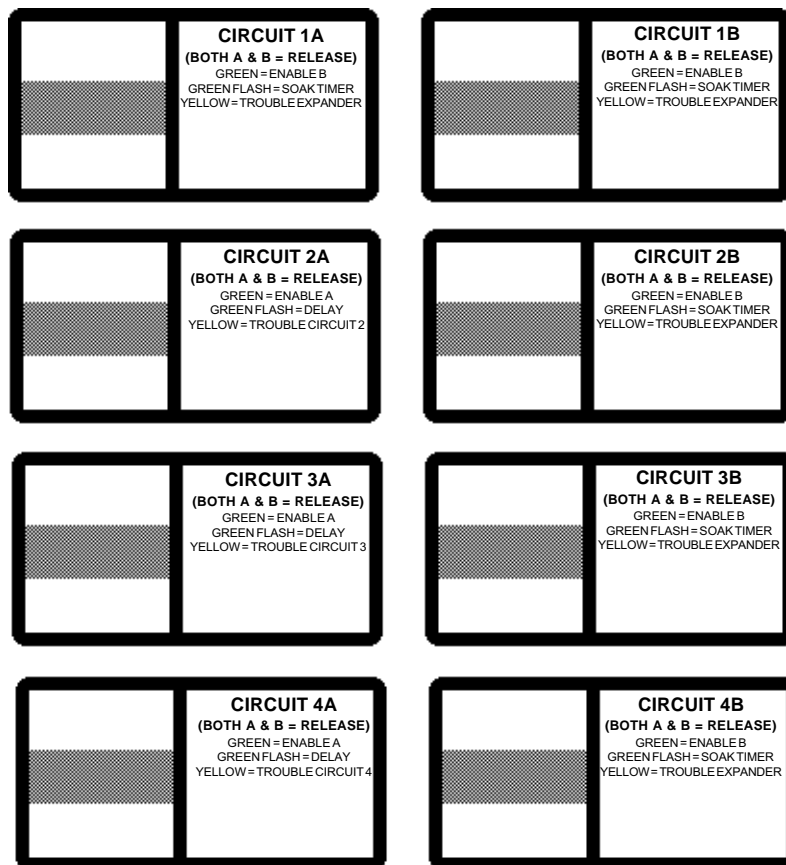

TC-4F Multi-Hazard Release Labels on a Sensican 2000 Dress Panel

Soak Timer

An optional soak timer may be programmed per circuit. This timer will automatically turn off the circuit 10 minutes after it has been energized. If another release circuit is activated, the soak timer will be restarted and the soak time for the first release will be increased. When this timer is active, the green LED for Enable B will flash. When this timer has expired, the green LED for Enable B will stay on steady.

Manual Release

Manual release may be achieved by alarming an initiating zone that has been mapped to both Enables A and B. If the delay timer option is selected, the release will occur after the timer has expired.

Dual Code Alert/Evacuation Operation

General

Each notification circuit can operate in the alert or evacuation state. In the alert state, the notification circuit pulses at 20 PPM (20 pulses per minute). When in the evacuation state, the notification circuit pulses at 120 PPM.

Each notification circuit on the TC-4F has an alert and an evacuation selection input. These inputs can be mapped to any one or any group of initiating zones. If both alert and evacuation are selected, the evacuation takes precedence and the alert LED is turned off.

Alert Timer

When an alert input is activated, a 5-minute alert timer starts. The green LED will flash and the notification circuit will pulse at 20 PPM. This timer is not adjustable.

When the alert timer expires, the notification circuit automatically changes to 120 PPM. At this time the Alert LED is turned off and the Evacuation LED turns on steady.

Note: There is only one alert timer on the TC-4F. If this timer is selected for a notification circuit and an alert for a second notification circuit is then selected, the timer will not be restarted. The second circuit will change to evacuation in less than 5 minutes.

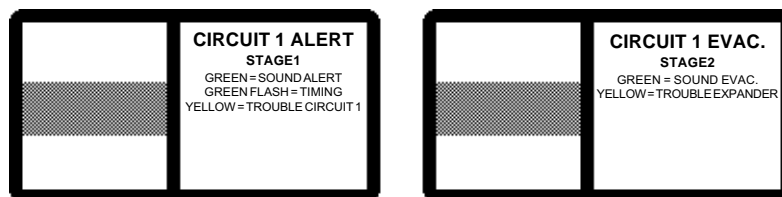

TC-4F Alert/Evacuation Labels on a Sensican 2000 Dress Panel

Evacuation

When an evacuation input has been activated, the notification circuit will ring at 120 PPM and the green evacuation LED for that circuit will turn on. If the circuit is already in the alert state, the evacuation signal will take precedence and the alert LED will be turned off.

NOTES

NOTES

Slide-In Labels for the TC-4F

Remove this page from the manual and careful cut along the dotted line for TC-4F labels. Custom information may be typed onto these labels in the window space provided. Insert labels into the slots on the dress panel (Sensican 2000).

| <i>Multi-Hazard Release Labels</i> | | <i>Dual-Stage Alert Evacuation Labels</i> | |
|--|--|---|--|
| Left-side | Right-side | Left-side | Right-side |
| | | | |
| CIRCUIT 1A (BOTH A & B = RELEASE) GREEN = ENABLE A GREEN FLASH = DELAY YELLOW = TROUBLE CIRCUIT 1 | CIRCUIT 1B (BOTH A & B = RELEASE) GREEN = ENABLE B GREEN FLASH = SOAK TIMER YELLOW = TROUBLE EXPANDER | CIRCUIT 1 ALERT STAGE1 GREEN = SOUND ALERT GREEN FLASH = TIMING YELLOW = TROUBLE CIRCUIT 1 | CIRCUIT 1 EVAC. STAGE2 GREEN = SOUND EVAC. YELLOW = TROUBLE EXPANDER |
| CIRCUIT 2A (BOTH A & B = RELEASE) GREEN = ENABLE A GREEN FLASH = DELAY YELLOW = TROUBLE CIRCUIT 2 | CIRCUIT 2B (BOTH A & B = RELEASE) GREEN = ENABLE B GREEN FLASH = SOAK TIMER YELLOW = TROUBLE EXPANDER | CIRCUIT 2 ALERT STAGE1 GREEN = SOUND ALERT GREEN FLASH = TIMING YELLOW = TROUBLE CIRCUIT 2 | CIRCUIT 2 EVAC. STAGE2 GREEN = SOUND EVAC. YELLOW = TROUBLE EXPANDER |
| CIRCUIT 3A (BOTH A & B = RELEASE) GREEN = ENABLE A GREEN FLASH = DELAY YELLOW = TROUBLE CIRCUIT 3 | CIRCUIT 3B (BOTH A & B = RELEASE) GREEN = ENABLE B GREEN FLASH = SOAK TIMER YELLOW = TROUBLE EXPANDER | CIRCUIT 3 ALERT STAGE1 GREEN = SOUND ALERT GREEN FLASH = TIMING YELLOW = TROUBLE CIRCUIT 3 | CIRCUIT 3 EVAC. STAGE2 GREEN = SOUND EVAC. YELLOW = TROUBLE EXPANDER |
| CIRCUIT 4A (BOTH A & B = RELEASE) GREEN = ENABLE A GREEN FLASH = DELAY YELLOW = TROUBLE CIRCUIT 4 | CIRCUIT 4B (BOTH A & B = RELEASE) GREEN = ENABLE B GREEN FLASH = SOAK TIMER YELLOW = TROUBLE EXPANDER | CIRCUIT 4 ALERT STAGE1 GREEN = SOUND ALERT GREEN FLASH = TIMING YELLOW = TROUBLE CIRCUIT 4 | CIRCUIT 4 EVAC. STAGE2 GREEN = SOUND EVAC. YELLOW = TROUBLE EXPANDER |

Type appropriate information into label windows above before cutting these labels from the page