

CP355 Plug-in Addressable Ionization Sensor Installation and Maintenance Instructions

GENERAL DESCRIPTION

This sensor must be installed in compliance with the control panel system installation manual. The installation must meet the requirements of the Authority Having Jurisdiction (AHJ). Sensors offer maximum performance when installed in compliance with the National Fire Protection Association (NFPA); see NFPA 72.

Model CP355 intelligent ionization sensor uses a state-of-the-art sensing chamber. This sensor is designed to provide open area protection and is intended for use with compatible control panels only.

Two LEDs on each sensor light to provide a local, visible sensor indication. Remote LED annunciator capability is available as an optional accessory (Part No. RA400Z).

The CP355 requires compatible addressable communications to function properly. Connect this sensor to listed-compatible control panels only.

SPECIFICATIONS

Operating Voltage Range:	15 to 32 VDC
Max. Avg. Standby Current:	300 μ A @ 24 VDC (one communication every 5 sec. with LED blink enabled)
Max. Alarm Current (LED on):	6.5 mA @ 24 VDC
Operating Humidity Range:	10% to 93% Relative Humidity, noncondensing
Operating Temperature Range:	0° to 49°C (32° to 120°F)
Height:	1.7 inches (43 mm) installed in B350LP Base
Diameter:	6.1 inches (155 mm) installed in B350LP Base
Weight:	3.6 oz. (102 g)

SPACING

Fire•Lite recommends spacing sensors in compliance with NFPA 72. In low air flow applications with smooth ceilings, space sensors 30 feet apart. For specific information regarding sensor spacing, placement, and special applications, refer to NFPA 72 or the System Smoke Detector Application Guide, available from Fire•Lite.

WIRING GUIDE

All wiring must be installed in compliance with the National Electrical Code, applicable local codes, and any special requirements of the Authority Having Jurisdiction. Proper wire gauges should be used. The installation wires should be color-coded to limit wiring mistakes and ease system trouble-shooting. Improper connections will prevent a system from responding properly in the event of a fire.

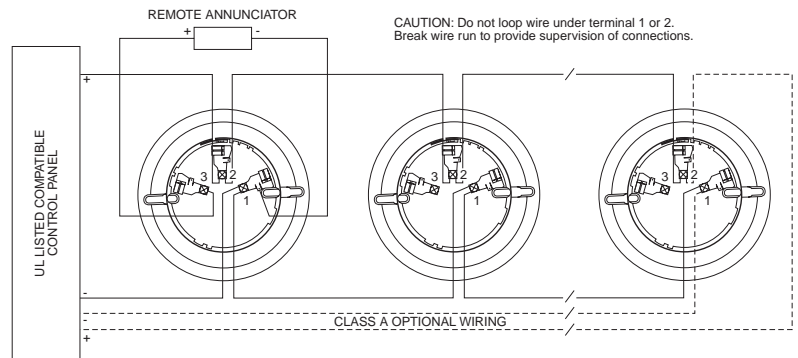

Figure 1.

Remove power from the communication line before installing sensors.

1. Wire the sensor base (supplied separately) per the wiring diagram, see Figure 1.
2. Set the desired address on the sensor address switches, see Figure 2.
3. Install the sensor into the sensor base. Push the sensor into the base while turning it clockwise to secure it in place.
4. After all sensors have been installed, apply power to the control unit and activate the communication line.
5. Test the sensor(s) as described in the TESTING section of this manual.

CAUTION

Dust covers provide limited protection against airborne dust particles during shipping. Dust covers must be removed before the sensors can sense smoke. Remove sensors prior to heavy remodeling or construction.

6. Tamper-Resistance

- Model CP355 includes a tamper-resistant capability that prevents its removal from the bracket without the use of a tool. Refer to the base manual for details on making use of this capability.
7. After all sensors have been installed, apply power to the system.
 8. See Figure 3. Test the sensor by positioning a test magnet against the sensor plastic in the magnet test area. The alarm level should be recognized at the panel and the LED controlled by communication command from the panel.
 9. Reset the sensor by communication command from the panel.

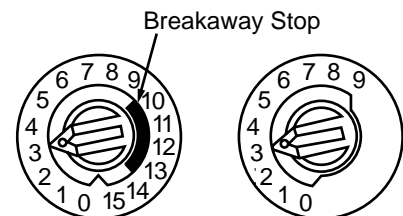

Figure 2.

TESTING

Detectors must be tested after installation and following periodic maintenance. However, before testing, notify the proper authorities that the smoke detector system is undergoing maintenance and the system will be temporarily out of service. Disable the zone or system undergoing maintenance to prevent unwanted alarms.

Testing methods must satisfy the Authority Having Jurisdiction (AHJ). Sensors offer maximum performance when tested and maintained in compliance with NFPA 72.

Test the sensors as follows:

A. Functional: Magnet Test (P/N M02-04-01 or M02-09-00)

This sensor can be functionally tested with a test magnet. The test magnet electronically simulates smoke in the sensing chamber, testing the sensor electronics and connections to the control panel.

1. Hold the test magnet in the magnet test area as shown in Figure 3.
2. The sensor should alarm the panel.

Two LEDs on the sensor are controlled by the panel to indicate sensor status. Coded signals, transmitted from the panel, can cause the LEDs to blink, latch on, or latch off. Refer to the control panel technical documentation for sensor LED status operation and expected delay to alarm.

B. Smoke Entry: Aerosol Generator (Gemini 501)

The GEMINI model 501 aerosol generator can be used for smoke entry testing. Set the generator to represent 4%/ft to 5%/ft obscuration as described in the GEMINI 501 manual. Using the bowl shaped applicator, apply aerosol until the panel alarms.

A sensor that fails any of these tests should be cleaned as described under CLEANING, and retested. If the sensor fails after cleaning, it must be replaced.

When testing is complete, restore the system to the normal operation and notify the proper authorities that the system is back in operation.

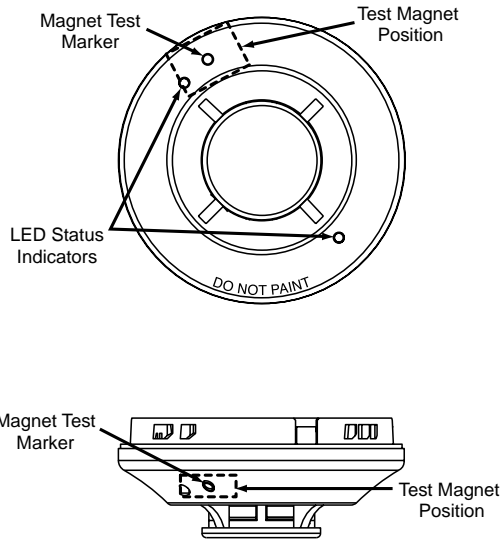
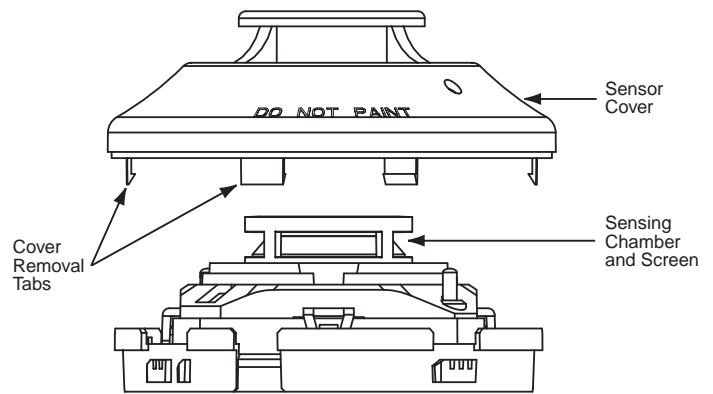

Figure 3. Test Magnet Positioning

CLEANING

Before cleaning, notify the proper authorities that the system is undergoing maintenance and will be temporarily out of service. Disable the system to prevent unwanted alarms.

1. Remove the sensor to be cleaned from the system.
2. Remove the sensor cover. Press firmly on each of the four removal tabs that hold the cover in place.
3. Vacuum the outside of the screen carefully. If further cleaning is required, continue with Step 4, otherwise skip to Step 5.
4. Use clean, compressed air to remove dust and debris from the sensing chamber.
5. Replace the cover using the LEDs to align the cover and then gently pushing it until it locks into place.
6. Reinstall the detector.
7. Test the detector as described in TESTING.
8. Reconnect disabled circuits.
9. Notify the proper authorities that the system is back on line.



A78-2737-01

Figure 4. Cleaning

Please refer to insert for the Limitations of Fire Alarm Systems

FCC Statement

This device complies with part 15 of the FCC Rules. Operation is subject to the following two conditions: (1) This device may not cause harmful interference, and (2) this device must accept any interference received, including interference that may cause undesired operation.

Note: This equipment has been tested and found to comply with the limits for a Class B digital device, pursuant to Part 15 of the FCC Rules. These limits are designed to provide reasonable protection against harmful interference in a residential installation. This equipment generates, uses and can radiate radio frequency energy and, if not installed and used in accordance with the instructions, may cause harmful interference to radio communications. However, there is no guarantee that interference will not occur in a particular installation. If this equipment does cause harmful interference to radio or television reception, which can be determined by turning the equipment off and on, the user is encouraged to try to correct the interference by one or more of the following measures:

- Reorient or relocate the receiving antenna.
- Increase the separation between the equipment and receiver.
- Connect the equipment into an outlet on a circuit different from that to which the receiver is connected.
- Consult the dealer or an experienced radio/TV technician for help.