

[12] Model D350P Air Duct Smoke Detector Specifications

Operating Voltage Range	15 to 32 VDC
Standby Current	300 μ A @ 24 VDC (one communication every 5 seconds with LED blink enabled)
Operating Temperature	+32° to +131°F (0° to +55°C)
Storage Temperature	-22° to +158°F (-30° to +70°C)
Humidity Range	10% to 93% (non-condensing)
Air Velocity	500 to 4000 ft/min (2.54 to 20.32 m/sec)
Dimensions	14 $\frac{3}{8}$ " L x 5 $\frac{1}{2}$ " W x 2 $\frac{3}{4}$ " D (37 cm L x 14 cm W x 7 cm D)

Programming Specifications/Requirements for Intelligent System Control Panels

There are a limited number of devices that can have their LEDs programmed to illuminate. The actual number of devices is determined by the control panel and its ability to supply LED current. Refer to the Control Panel Installation Manual for details.

Accessories	Part No.
Remote LED	RA400Z
Magnetic Remote Test	RTS451
Key-Activated Remote Test	RTS451KEY
Replacement Filters	F36-09-11
Replacement Test Magnet	M02-04-00
Replacement Photo Insect Screen	S08-39-01
Replacement End Cap for Plastic Sampling Tube	P48-61-00
Replacement End Cap for Metal Sampling Tubes	P48-21-00
Replacement Photoelectric Sensor Board	A5053FL
Replacement Power Board (w/o relay)	A5067



**D350P INTELLIGENT PHOTOELECTRONIC DUCT SMOKE DETECTOR
INSTALLATION AND MAINTENANCE INSTRUCTIONS**

Before installing detectors, please thoroughly read the NEMA *Guide for Proper Use of Smoke Detectors in Duct Applications*, which provides detailed information on detector spacing, placement, zoning, wiring, and special applications. Copies of this manual are available from NEMA (National Electrical Manufacturers Association, 2101 L Street NW, Washington, DC 20037). NFPA Standards 72 and 90A should also be referenced for detailed information.

NOTICE: This manual shall be left with the owner/user of this equipment.

IMPORTANT: This detector must be tested and maintained regularly following NFPA 72 requirements. The detector should be cleaned at least once a year.

GENERAL DESCRIPTION

An HVAC system supplies conditioned air to virtually every area of a building. Smoke introduced into this air duct system is distributed to the entire building. Smoke detectors designed for use in air duct systems are used to sense the presence of smoke in the duct.

The D350P air duct smoke detector is a photoelectric detector. This smoke detection method combines with an efficient housing design that samples air passing through a duct and allows detection of a developing hazardous condition. When sufficient smoke is sensed, an alarm signal is initiated at the fire control panel monitoring the detector, and appropriate action can be taken to shut off fans, blowers and change over air handling systems, etc. This can prevent the distribution or it can isolate toxic smoke and fire gases throughout the areas served by the duct system.

Two LEDs on each detector may illuminate, if programmed by the system control panel, to provide a local alarm indication. There is also a remote alarm output for use with auxiliary devices. The D350P has remote test capability with the RTS451/RTS451KEY Remote Test Station.

CONTENTS OF THE DUCT SMOKE DETECTOR HOUSING KIT

The D350P Duct Smoke Detector consists of the following items: (See Figure 1.)

Figure 1: Exploded View Of Duct Smoke Detector Components

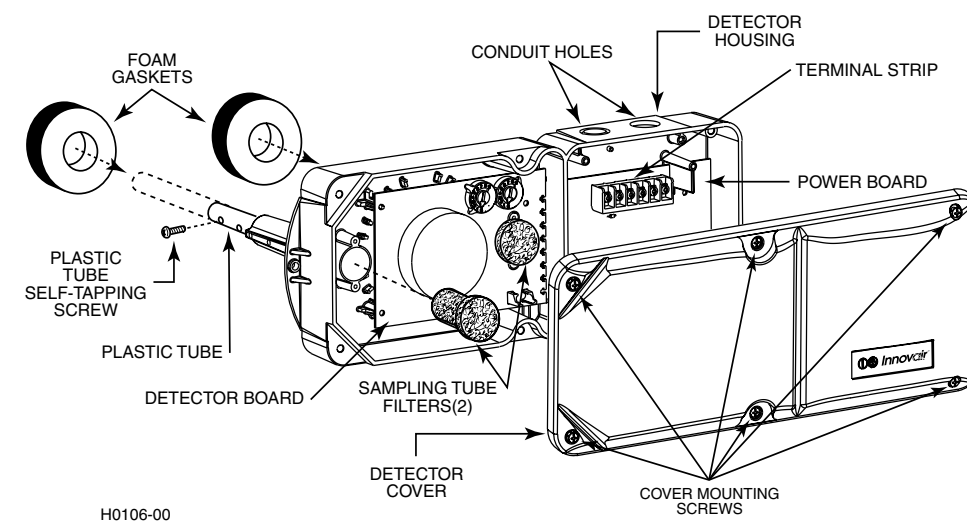

Contents Of The Duct Smoke Detector

1. Complete duct smoke detector assembly with sensor
2. Two #10 x 1 $\frac{1}{4}$ " sheet metal mounting screws
3. Two sampling tube filters
4. One test magnet
5. Drilling template
6. Two foam gaskets
7. Four #6-self tapping mounting screws for the sampling tube and optional exhaust tube extension
8. One sampling tube end cap
9. One plastic sampling tube
10. One #8 self-tapping screw for plastic sampling tube

NOTE: A detector sensor board DOES NOT need to be ordered separately.

NOTE: For ducts over 1 $\frac{1}{2}$ feet, longer sampling tubes must be ordered to complete the installation. They must be the correct length for the width of the duct where they will be installed. See Table 1 on page 3 to determine the sampling tube required for different duct widths.

Please refer to insert for the Limitations of Fire Alarm Systems

To keep your equipment in excellent working order, ongoing maintenance is required per the manufacturer's recommendations and UL and NFPA standards. At a minimum, the requirements of Chapter 7 of NFPA 72, the National Fire Alarm Code, shall be followed. A preventative maintenance agreement should be arranged through the local manufacturer's representative. Though smoke detectors are designed for long life, they may fail at any time. Any smoke detector, fire alarm equipment, or any component of that system which fails shall be repaired or replaced as soon as possible.

FCC Statement

This device complies with part 15 of the FCC Rules. Operation is subject to the following two conditions: (1) This device may not cause harmful interference, and (2) this device must accept any interference received, including interference that may cause undesired operation.

Note: This equipment has been tested and found to comply with the limits for a Class B digital device, pursuant to Part 15 of the FCC Rules. These limits are designed to provide reasonable protection against harmful interference in a residential installation. This equipment generates, uses and can radiate radio frequency energy and, if not installed and used in accordance with the instructions, may cause harmful interference to radio communications. However, there is no guarantee that interference will not occur in a particular installation. If this equipment does cause harmful interference to radio or television reception, which can be determined by turning the equipment off and on, the user is encouraged to try to correct the interference by one or more of the following measures:

- Reorient or relocate the receiving antenna.
- Increase the separation between the equipment and receiver.
- Connect the equipment into an outlet on a circuit different from that to which the receiver is connected.
- Consult the dealer or an experienced radio/TV technician for help.

WARNING
LIMITATIONS OF DUCT DETECTORS



The National Fire Protection Association has established that DUCT DETECTORS MUST NOT BE USED AS A SUBSTITUTE FOR OPEN AREA DETECTOR PROTECTION as a means of providing life safety. Nor are they a substitute for early warning in a building's regular fire detection system.

It is strongly recommended that the user read NFPA Standards 90A, 72, and 101.



This device will not operate without electrical power. Fire situations may cause an interruption of power. The system safeguards should be discussed with your local fire protection specialist.



This device will not sense smoke unless the ventilation system is operating.



In order to function properly, this detector must be installed according to the instructions. Do not exceed the electrical or ambient specifications or the detector will not function properly. This detector must be protected from the elements.

INSTALLATION SEQUENCE

Step 1. Verify duct air flow direction and velocity	2
Step 2. Drill the mounting holes	2
Step 2.1 Install the sampling tube for ducts less than 1½ feet wide.....	2
Step 3. Secure the detector housing to the duct.....	3
Step 4. Install the sampling tube for ducts greater than 1½ feet wide	3
Step 4.1 Installation for ducts greater than 1½ feet but less than 8 feet wide	3
Step 4.2 Installation for ducts more than 8 feet wide	4
Step 5. Install the filters	4
Step 6. Field wiring	4
Step 7. Perform detector check.....	5
Step 8. Install the cover.....	5
Step 9. Detector Maintenance and Test Procedures.....	5

[1] Verify Duct Air Flow Direction And Velocity

The D350P duct smoke detector is designed to be used in air handling systems having air velocities of 500 to 4000 feet per minute. Be sure to check engineering specifications to ensure that the air velocity in the duct falls within these parameters. If necessary, use a velocity meter to check the air velocity in the duct.

[2] Drill The Mounting Holes

Remove the paper backing from the mounting template supplied. Affix the template to the duct at the desired mounting location. Make sure the template lies flat and smooth on the duct. Center punch holes A and B. Drill the holes as indicated on the template.

[2.1] Sampling Tube Installation for Ducts Less Than 1½ Feet Wide (see Figure 2)

1. Remove the front cover.
2. Slide the plastic sampling tube into the housing bushing and extend it the full width of the duct.
3. Align the holes in the bushing with the holes in the sampling tube. Secure with the #8 self-tapping screw into the bottom of the permanent tube. (Shown in figure 2.)

NOTE: The sampling tube end cap is critical to the proper operation of the duct smoke detectors. The end cap is needed to create the proper air flow to the sensor of the duct smoke detector.

NOTE: For ducts greater than 1½ feet in width, refer to sections [4], [4.1] and [4.2].

Figure 2. Plastic sampling tube connected to duct smoke detector

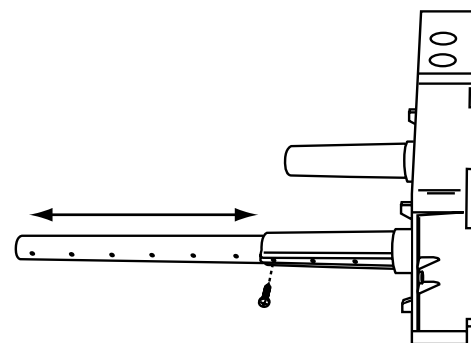

[9.2.2] Alarm Tests

[9.2.2.1] M02-04-00 Magnet Test

1. Place the painted surface of the magnet onto the TEST locator on the bottom of the detector housing (Figure 11).
2. Verify system control panel alarm status and control panel execution of all intended auxiliary functions (i.e. fan shutdown, damper control, etc.)
3. The detector is self-restoring when the magnet is removed. Verify that the system control panel has reset.

[9.2.2.2] RTS451/RTS451KEY Remote Station Test

The RTS451/RTS451KEY Remote Test Station facilitates test of the alarm capability of the duct smoke detector. These accessories provide the stimulus to initiate an alarm condition at the detector. The detector is self-restoring when the accessory test stimulus is removed. Verify that the system control panel has reset.

Figure 11. Testing detector alarm:

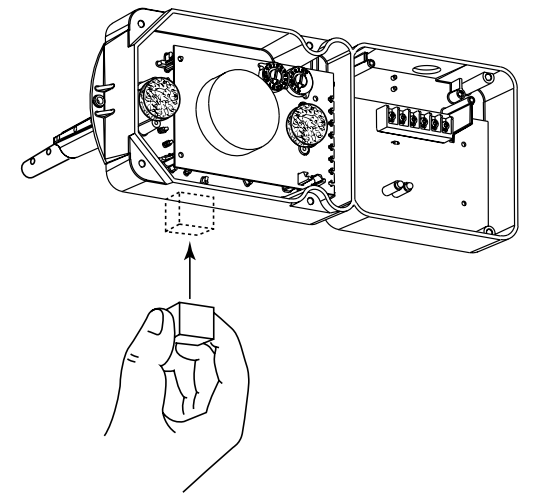

[9.2.3] Sensitivity Tests

Notify the proper authorities that the smoke detector system is undergoing maintenance, and that the system will temporarily be out of service. Disable the device or system undergoing maintenance to prevent unwanted alarms and possible dispatch of the fire department.

[9.3] Maintenance of Duct Smoke Detectors

[9.3.1] Air Filters

1. Turn off power to the system.
2. Remove and inspect sampling tube filters.
3. If filters are heavily coated with dirt, replace them with new filters (p/n F36-09-11). If they are not heavily coated, use a vacuum cleaner or compressed air nozzle to remove dust, then reinstall the filters.

[9.3.2] Photo Detector Boards

1. Remove the screen by gently grasping on each side and pulling straight off
2. Lift the photo chamber in the same fashion. Vacuum the screen and cover. Use clean, compressed air to loosen and blow out any remaining debris. Replacement screens (p/n S08-39-01) are available.
3. Vacuum photo chamber, then use clean compressed air to blow area clean.
4. Replace the chamber by pressing it onto the base. Press the screen into place. It should fit tightly on the chamber.

[10] Board Replacement

[10.1] Sensor Board Replacement

1. Remove the two sensor board mounting screws.
2. Pull gently on the board to remove it.
3. To replace the board, align the board mounting features, holes, and the interconnect terminals. Push the board into place.
4. Secure board with the two mounting screws.

[10.2] Power Board Replacement

1. Disconnect wiring from the terminal block.
2. Remove the two power board mounting screws.
3. Pull gently on the board to remove it.
4. To replace the board, align the board mounting features, holes, and the interconnect terminals. Push the board into place.
5. Secure board with the two mounting screws.
6. Re-connect wiring to terminal block.

[9.1.1] Smoke Response

To determine if smoke is capable of entering the sensing chamber, visually identify any obstructions. Plug the exhaust and sampling tube holes to prevent ducted air from carrying smoke away from the detector head, then blow smoke such as cigarette, cotton wick, or punk directly at the head to cause an alarm. **REMEMBER TO REMOVE THESE PLUGS AFTER THIS TEST, OR THE DETECTOR WILL NOT FUNCTION PROPERLY.**

[9.1.2] Filter Replacement

The filters do not substantially affect smoke performance even when up to 90% of the filter is clogged. Quarterly visual inspection usually suffices to determine whether the filters should be replaced because only a high percentage of contamination affects performance. If further testing is required, compare differential pressure readings with and without the filters installed using a manometer. If the difference exceeds 10%, replace the filters. In no case should the pressure differential fall below 0.03 inches of water.

[9.2] Standby, Alarm, And Sensitivity Tests

[9.2.1] Standby And Trouble

- Standby** — If programmed by the system control panel, look for the presence of the flashing LEDs through the transparent housing cover. The LED will flash with each communication.
- Trouble** — If programmed by the system control panel and the detector LEDs do not flash, then the detector lacks power (check wiring, panel programming, or power supply), the detector board is missing (replace), or the unit is defective (return for repair).
- Test** — The trouble condition can be caused intentionally to verify correct operation of the system. Remove the detector board to cause a trouble condition locally and at the system control panel.

Figure 8. Wiring Diagram for D350P Duct Smoke Detector using a UL listed control panel

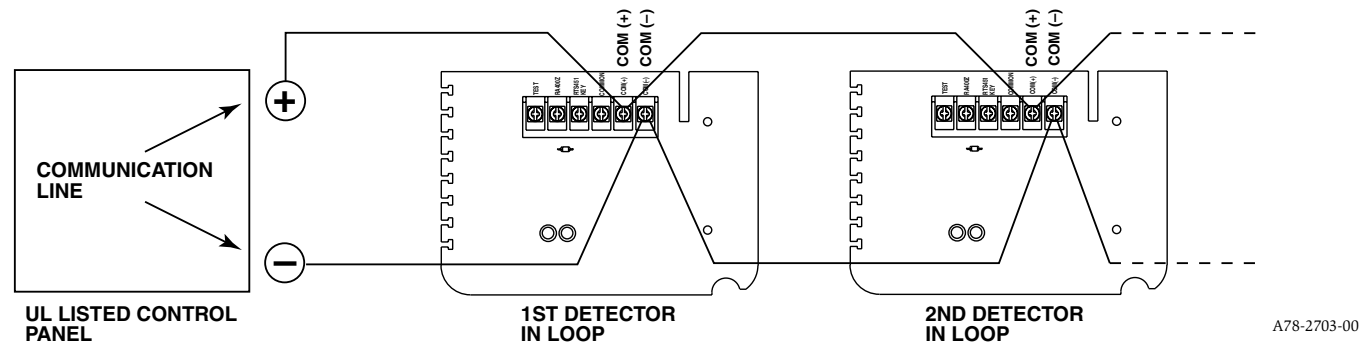

Figure 9. Wiring Diagram for D350P Duct Detector with optional RA400Z

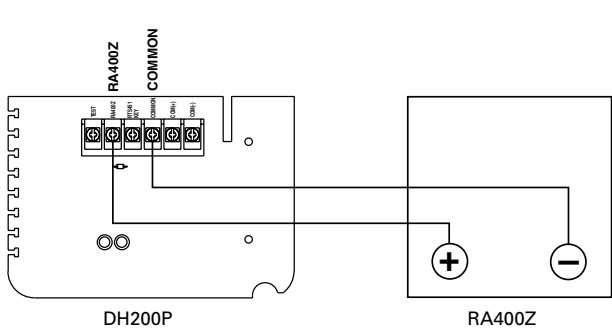
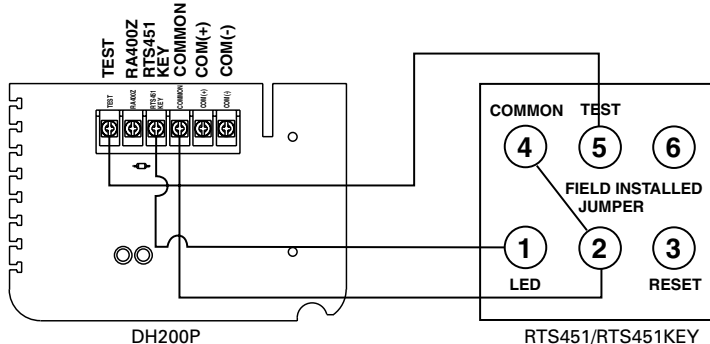

Figure 10. System Wiring Diagram for D350P Duct Smoke Detector with RTS451/RTS451KEY



FOR RTS451, TERMINAL 3 IS NOT USED. (RTS451 DOES NOT HAVE A TERMINAL 6.)
FOR RTS451KEY, TERMINALS 3 AND 6 ARE NOT USED.

Accessory Current Loads at 24VDC

DEVICE	STANDBY	ALARM
RA400Z	0mA	10 mA Max.
RTS451/RTS451KEY	0mA	7.5 mA Max.

COIL NOTE

Please note that the magnetic coil supplied with the RTS451 and RTS451KEY is **not required** when these accessories are used with the D350P detectors. The functionality of the magnetic coil has been designed into the circuitry of the duct smoke detector.

[3] Secure The Detector Housing To The Duct

Slide the foam gaskets over the tube bushings as shown in Figure 3. Use the two 1¹/₄" long sheet metal screws to screw the detector housing to the duct.

CAUTION: Do not overtighten the screws.

[4] Sampling Tube Installation for Ducts Greater Than 1½ Feet Wide

The sampling tube is identified by a series of air inlet holes on the tube. A plastic tube is included for ducts up to 1½ feet wide. All other lengths must be purchased separately. Order the correct length, as specified in Table 1, for width of the duct where it will be installed. It is recommended that the sampling tube length extend at least ¾ across the duct width for optimal performance. The exhaust tube is molded onto the base of the duct housing, and the A2440-00 Exhaust Tube Extension is available as an accessory in those cases where the molded exhaust port does not extend at least 2 inches into the duct.

The sampling tube is always installed with the air inlet holes facing into the air flow. To assist proper installation, the tube's mounting flange is marked with an arrow. Make sure the sampling tube is mounted so that the arrow points into the air flow (see Figure 4). Figure 5 shows the various combinations of tube mounting configurations with respect to air flow. Mounting the detector housing in a vertical orientation is acceptable, provided that a metal sampling tube is used and the air flows directly into the sampling tube holes as indicated in Figure 4.

[4.1] Installation For Ducts Greater Than 1½ Feet But Less Than 8 Feet Wide

- If the tube is longer than the width of the air duct, drill a 3/8" hole in the duct opposite the hole already cut for the sampling tube. Make sure the hole is 1" to 2" below the inlet hole on the opposite side of the duct to allow moisture drainage away from the detector. If the tube is shorter than the width of the air duct, install the end cap into the sampling tube as shown in Figure 4. Sampling tubes over 3 ft. long must be supported at the end opposite the duct smoke detector.
- Slide the tube into the housing bushing that meets the air flow first. Position the tube so that the arrow points into the air flow, as shown in Figure 4.
- Secure the tube flange to the housing bushing with two #6 self-tapping screws.
- For tubes longer than the width of the air duct, the tube should extend out of the opposite side of the duct. If there are more than 2 holes in the section of the tube extending out of the duct, select a different length using Table 1. Otherwise, trim the end of the tube protruding through the duct so that 1" to 2" of the tube extend outside the duct. Plug this end with the end cap and tape closed any holes in the protruding section of the tube. Be sure to seal the duct where the tube protrudes.

NOTE: The sampling tube end cap is critical to the proper operation of the duct smoke detectors. The end cap is needed to create the proper air flow to the sensor of the duct smoke detector.

Figure 3. Installation of foam gaskets over sampling tube bushings:

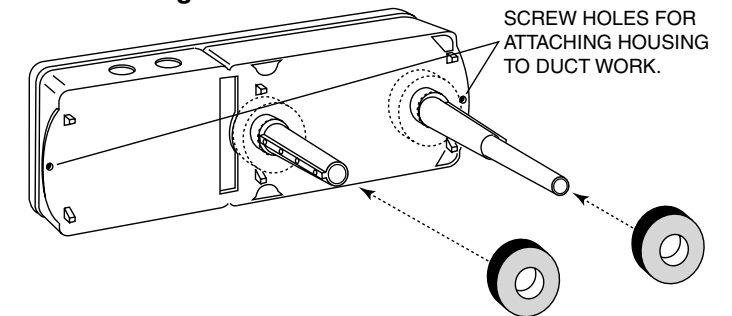

Table 1. Sampling tubes recommended for different duct widths:

Outside Duct Width	Sampling Tube Recommended*
1 to 2 ft. (0.3 to 0.6 m)	ST-1.5
2 to 4 ft. (0.6 to 1.2 m)	ST-3
4 to 8 ft. (1.2 to 2.4 m)	ST-5
8 to 12 ft. (2.4 to 3.7 m)	ST-10

*Must extend a minimum of ¾ the duct width.

Figure 4. Air duct detector sampling tube:

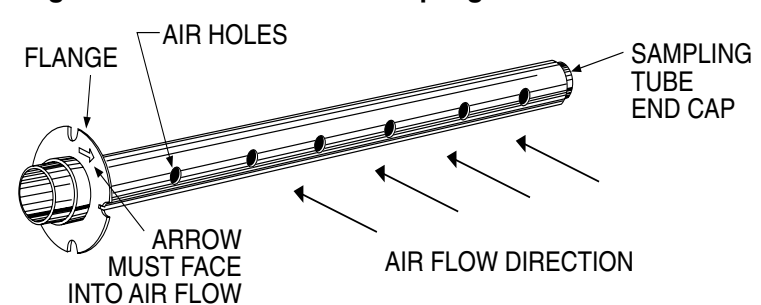
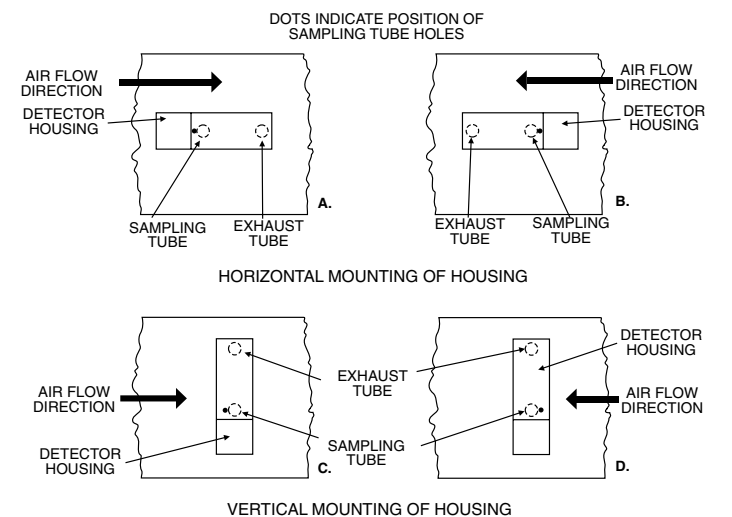

Figure 5. Tube mounting configurations with varying air flow direction:



NOTE: Only metal sampling tubes can be installed in orientations C and D.

[4.2] Installation For Ducts More Than 8 Feet Wide

NOTE: To install sampling tubes in ducts more than 8 feet wide, work must be performed inside the air duct. Sampling of air in ducts wider than 8 feet is accomplished by using the ST-10 sampling tube. If the tube is shorter than the width of the air duct, install the end cap into the sampling tube as shown in Figure 4 and support the end opposite the duct smoke detector.

Install the sampling tube as follows:

1. Drill a 3/4-inch hole in the duct directly opposite the hole already drilled for the sampling tube. Make sure the hole is 1" to 2" below the inlet hole on the opposite side of the duct to allow for moisture drainage.
2. Slide the sampling tube with the flange into the housing bushing that meets the air flow first. Position the tube so that the arrow points into the air flow. Secure the tube flange to the housing bushing with two #6 self-tapping screws.
3. From inside the duct, couple the other sections of the sampling tube to the section already installed using the 1/2-inch conduit fittings supplied. Make sure that the holes on both of the sampling tubes are lined up and facing into the air flow.
4. Trim the end of the tube protruding through the duct so that 1" to 2" of the tube extend outside the duct. Plug this end with the end cap and tape closed any holes in the protruding section of the tube. Be sure to seal the duct where the tube protrudes.

NOTE: An alternate method to using the ST-10 is to use two ST-5 sampling tubes. Remove the flange from one of the tubes and install as described above. After the installation, use electrical tape to close off some of the sampling holes so that there are a total of 10 to 12 holes spaced as evenly as possible across the width of the duct.

NOTE: Air currents inside the duct may cause excessive vibration, especially when the longer sampling tubes are used. In these cases a 3 inch floor flange (available at most plumbing supply stores) may be used to fasten the sampling tube to the other side of the duct. When using the flange/connector mounting technique, drill a 1-inch to

1 1/4-inch hole where the flange will be used.

Figure 6. Sampling tube filter installation:

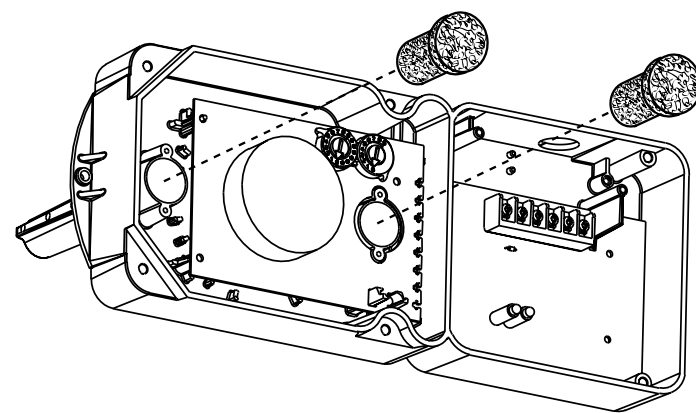

[5] Install The Filters

To install the sampling tube filters, simply push the filters into the sampling and exhaust tube holes, as shown in Figure 6. If a metal sampling tube is used, install the filters over the tube end.

[6] Field Wiring Installation Guidelines

All wiring must be installed in compliance with the National Electrical Code and the local codes having jurisdiction. Proper wire gauges should be used. The conductors used to connect smoke detectors to control panels and accessory devices should be color-coded to prevent wiring mistakes. Improper connections can prevent a system from responding properly in the event of a fire.

CAUTION

Filters require periodic cleaning or replacement, depending on the amount of dust and dirt accumulated. Visually inspect the filters at least quarterly; inspect them more often if the dust accumulation warrants it. See Section [9.1.2] for more information. Replacement filters can be ordered (filter P/N F36-09-11).

For signal wiring, (the wiring between detectors or from detectors to auxiliary devices), it is usually recommended that single conductor wire be no smaller than 18 gauge. The duct smoke detector terminals accommodate wire sizes up to 12 gauge. The last foot of conduit should be flexible conduit (available in electrical supply houses), which facilitates easier installation and puts less strain on the conduit holes in the housing. Solid conduit connections may be used if desired.

Smoke detectors and alarm system control panels have specifications for Signaling-Line Circuit (SLC) wiring. Consult the control panel manufacturer's specifications for wiring requirements for the particular model control panel being used before wiring the detector loop.

The D350P detector is designed for ease of wiring. The housing provides a terminal strip with clamping plates. Wiring connections are made by stripping about 3/8-inch of insulation from the end of the wire, sliding the bare end under the plate, and tightening the clamping plate screw.

Two LEDs on each duct smoke detector may light, if programmed by the system control panel, to provide a local, visible indication. Remote LED annunciator capability is available as an option. Each duct smoke detector can only be wired to one remote accessory.

Fire•Lite panels offer different feature sets across different panel models. As a result, certain features of the D350P may be available on some control panels, but not on others. The possible features available in the D350P, if supported by the control panel are:

1. Panel controls the LED operation on the duct smoke detector. Operational modes are RED blink, RED continuous, GREEN blink, GREEN continuous, and off.
2. The remote output may be synchronized to the LED operation or controlled independent of the LEDs.

Please refer to the operation manual for the UL listed control panel for specific operation of the D350P

WIRING INSTRUCTIONS

Disconnect power from the communication line before installing the D350P duct smoke detectors.

Wire the D350P duct smoke detector per the Control Panel Installation Manual and Figures 8, 9 or 10. Set the desired address on the sensor board code wheel address switches.

NOTE: Some panels support extended addressing. In order to set the sensor above address number 99 on compatible systems, carefully remove the stop on the left hand rotary switch with pliers as shown in Figure 7.

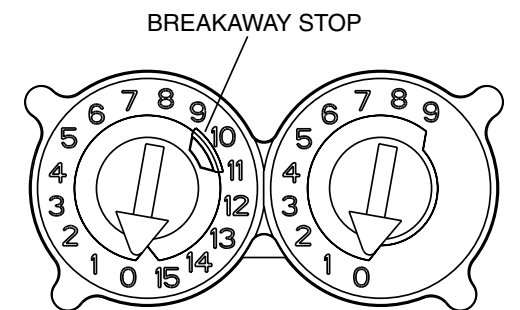

Figure 7. Rotary Address Switches

[7] Perform Detector Check

1. Perform STANDBY AND TROUBLE TEST per Section [9.2.1].
2. Perform MAGNET TEST per Section [9.2.2.1]. The RTS451 test of Section [9.2.2.2] may substitute for this requirement.
3. Perform AIR FLOW TEST per Section [9.1].
4. Perform SMOKE RESPONSE TEST per Section [9.1.1].

[8] Install The Cover

Install the cover using the six screws that are captured in the housing cover. Be certain filters are installed as specified in Section [5]. Make sure that the cover fits into the base groove and that all gaskets are in their proper positions. Tighten the six screws.

[9] Duct Smoke Detector Maintenance and Test Procedures

Test and maintain duct smoke detectors as recommended in NFPA 72. The tests contained in this manual were devised to assist maintenance personnel in verification of proper detector operation.

Before conducting these tests, notify the proper authorities that the smoke detection system will be temporarily out of service. Disable the device or system under test to prevent unwanted alarms.

Smoke Entry Tests

[9.1] Air Flow

To verify sufficient sampling of ducted air, use a manometer to measure the differential pressure created from air flow across the sampling tubes. The pressure should measure no less than 0.03 inches of water and no greater than 1.4 inches of water. The air handler must be operating for this test.