

# AC Terminal Block Installation on FACP Product Installation Drawing

Document 53545 Rev: A 10/30/08 ECN 08-808

**CAUTION! Before installing the Terminal Block, make certain that all power (AC and DC) has been removed from the panel.**

## AC Terminal Block Installation

The AC Terminal Block mounts to a metal bracket which, in turn, mounts to the FACP chassis. The following steps detail this installation:

1. Attach the supplied AC Terminal Block to the metal bracket using the two supplied 4-40 X 5/8 screws as illustrated in Figure 1.
2. Attach the metal bracket to the lower-left bottom of the FACP chassis, near the transformer, using the two supplied 6-32 X .37 screws as illustrated in Figure 1.

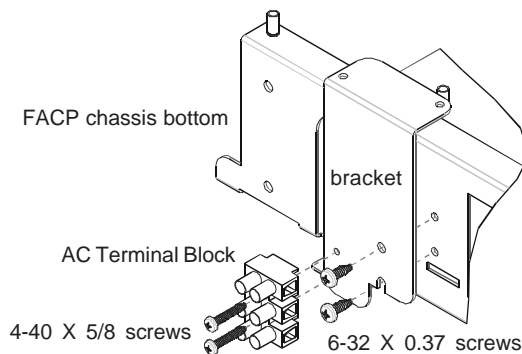

**Figure 1: AC Terminal Block Installation**

3. Connect the AC Power wires and the Transformer wires as illustrated in Figure 2.

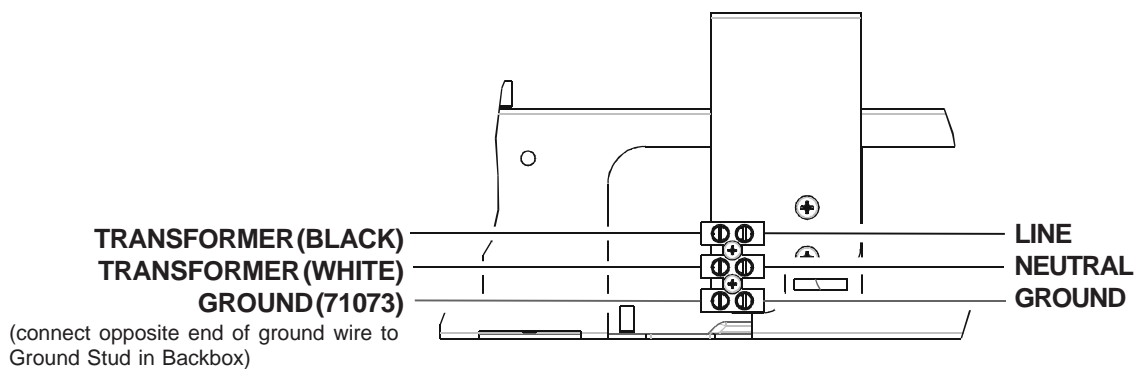

**Figure 2: Wire Connections To AC Terminal Block**

4. Connect ground wire (71073) ring lug to ground stud in backbox using supplied #8-32 nut.
5. Check to make certain that all wires have been securely connected and then apply power.