

# INSTALLATION AND MAINTENANCE INSTRUCTIONS



I56-3157-003R

## MDL3 Series Sync Module

For use with the following series models:

**UL & ULC listed models:** CHRX, CHWX, CHSRX, CHSWX, HRX, HWX, MHR(A), MHW(A), P2RX, P2WX, P4RX, P4WX, PC2WX, PC4RX, PC4WX, PC24XX, PC2RX, SCRX, SCWX, SC24XX, SRX, SWX, B200S(A), B200SR(A)

**UL listed:** SP2C24XX, SPSX, SPSCX

**ULC listed models:** HC12/24X, SPSX (V models only), SPSCX (V models only), MHRZA, MHWZA

**Obsolete models (for reverse compatibility reference):**

CHX, CH24MCX, H12/24X, PA400X, S1224MCX, SP2R1224MCX, SP2W1224MCX

Refer to System Sensor product installation manuals for model specifications.

3825 Ohio Avenue, St. Charles, Illinois 60174

1.800.SENSOR2; Fax: 630.377.6495

www.systemsensor.com



### SPECIFICATIONS

Input Voltage Range:		Regulated: 12VDC/FWR (8.0 to 17.5V); or 24VDC/FWR (16.0 to 33V)								<div style="border: 1px solid black; padding: 2px; display: inline-block;"><b>CAUTION</b></div> When Strobes are connected to sync module, MDL3 input voltage range at 12V: 8.5 to 17.5VDC/FWR; at 24V 16.5 to 33VDC/FWR
Maximum Load on Loop:		3 A								
Current:	Voltage	Average		Peak		In-rush		NAC Slave Input (3)		
		DC	FWR	DC	FWR	DC	FWR	DC	FWR	
	12 V	10mA	12mA	50mA	60mA	100mA	120mA	3.5mA	4mA	
24 V	12mA	15mA	60mA	75mA	120mA	150mA	4.5mA	5mA		
Operating Temperature:		32°F to 120°F (0°C to 49°C)								
Listings:		UL464, UL1971, ULC S525, ULC S526								
NOTE: 1) For maximum number of strobes and/or maximum line impedance, refer to the voltage drop calculator found at Systemsensor.com; and 2) Maximum line impedance as required by the fire alarm control manufacturer. 3) Average current draw of NAC Slave input when connected as in figure 3.										

### GENERAL DESCRIPTION

The MDL3 Module is designed to work with the SpectrAlert Advance series of notification appliances to provide a means of synchronizing the temporal-coded horns and chimes, synchronizing the one-second flash timing of the strobe, and silencing the horns and chimes of the horn/strobe and chime/strobes combination over a two-wire circuit while leaving the strobes active. MDL3 is intended to connect to UL or ULC listed FACP or its NAC accessories (e.g. a boost module, etc.)

NOTICE: This manual shall be left with the owner/user of this equipment.

### MODULE CONFIGURATION

Each MDL3 module has the capability of connecting two Style Y (Class B) circuits or one Style Z (Class A) circuit.

The zone output(s) from the panel are connected to the zone input(s) of the MDL3 module and the zone output(s) from the MDL3 module are connected to the notification loop(s). Supervision is accomplished in the module by a direct connection between the zone input and the zone output of each of the two zone circuits connected to the normal end-of-line device. The FACP “sees” the EOL device through the MDL3 module. When either or both outputs from the module are wired to the SpectrAlert Advance products, the horns or chimes and strobes in both zones will be synchronized.

The MDL3 module can be configured so that more than two zones can be synchronized by the interconnection of the slave input and output (see Figures 1, 2, and 3).

### SYNCHRONIZE SPECTRALERT ADVANCE HORNS, CHIMES AND STROBES

- Each module can power two 3-amp circuits wired in class B or one 3-amp circuit powered as Class A.
- Each module will synchronize 2 zones.
- Additional modules can be added and may be synchronized to all other modules by interconnecting the “slave” input and output terminals between modules.

### CONTROLLING SOUNDER ON/OFF OVER 2-WIRES USING MODULE HORN CONTROL

- Connect the current source to the horn control input. If a zone output is used for the source, you must use an EOL on the horn control input terminal, see Figure 1.
- When multiple modules are used, the horn control circuits can be wired in parallel. If wired in parallel and a zone output is used from panel, use an EOL on the last module for supervision.



Unless it’s supervised, Horn Control wiring must be contained within common enclosure of FACP

Slave Out – Slave In wiring must be contained within either the common enclosure of modules or enclosures within 20 feet of each other with wiring inside conduit. Reverse wiring will cause this input to malfunction.

If Zone 1 input is not powered or fails during alarm, the notification devices attached to the Zone 2 output will not be synchronized.

NOTE: Ground fault on a module’s two wire loop can be indicated at the control panel if the control panel is capable of ground fault detection on the power supply to the module and meets UL 864 9th Edition ground fault indication requirements for initiating device circuits. The installer must verify that capability.

Zone 1 – NAC slave wiring must be dedicated to sync purposes. No devices shall be attached. EOL must be used on the last MDL3 for supervision. (1) The value of EOL should refer to FACP specification or installation instruction.

### FIGURE 1. HORNS SILENCED OVER TWO WIRE CIRCUIT:

NOTE: If zone 1 output of module is connected to strobes, chime/strobes or horn/strobes, zone 1 input supply power must be continuous for proper operation.

Zone 1 Input	This input powers the MDL3 module. This input must have voltage present from the FACP before anything will work. This also supplies voltage to Zone 1 output.
Zone 2 Input	This input only supplies voltage to Zone 2 output. Note: If Zone 1 input is not powered, the notification devices attached to the Zone 2 output will be out of synch.
Horn Control	This input enables the horns on the SpectrAlert Advance notification appliances. Voltage present means horns are enabled. No voltage present means horns are disabled.
Slave In	Connects to Master MDL3 Module slave out. A maximum of 11 slave MDL3 modules can be connected to a Master MDL3.
Slave Out	Connects to Slave MDL3 slave in.
NAC Slave In	Connects to slave MDL3 from NAC. A dedicated NAC should be used for slaving purposes.

**MASTER MODULE HORN CONTROL CONNECTS TO INTERRUPTIBLE POWER SOURCE**

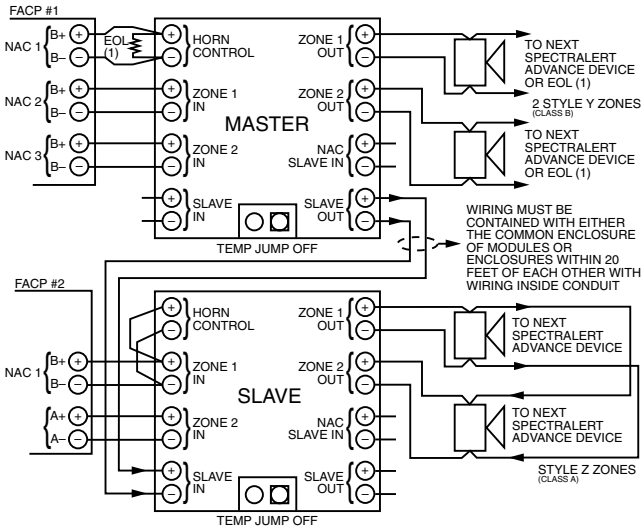

A0414-01

**FIGURE 2 MASTER-SLAVE MODE:**

NOTE: If zone 1 output of module is connected to strobes, chime/strobes or horn/strobes, zone 1 input supply power must be continuous for proper operation.

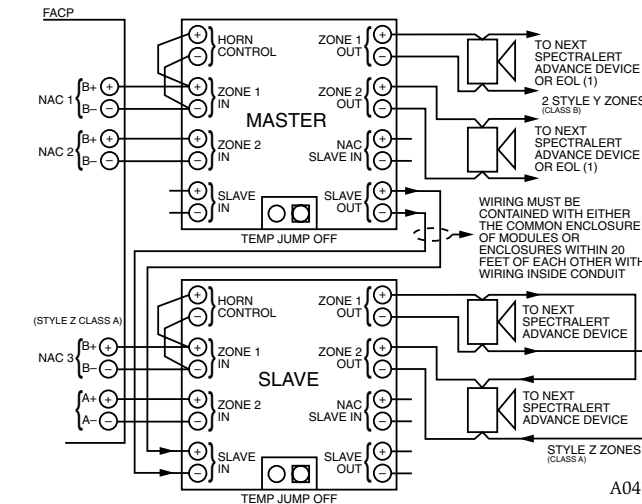

A0415-01

**FIGURE 3. MASTER-SLAVE USING NAC-SLAVE INPUT:**

NOTE: If zone 1 is connected to synchronize other MDL3 no devices shall be attached to this zone. Zone 1 input supply power must be continuous to be operational.

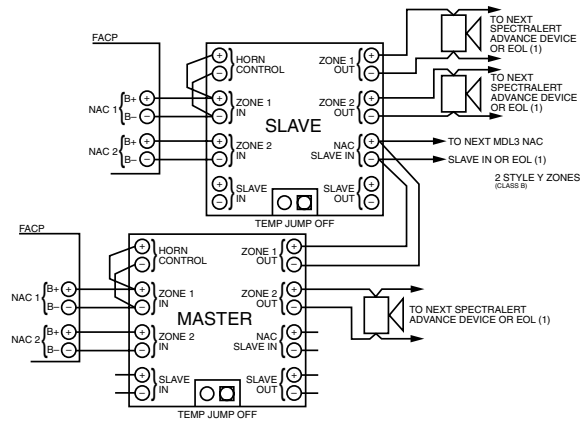

A0416-01

**FIGURE 4. WIRING FOR CODED SUPPLIES:**

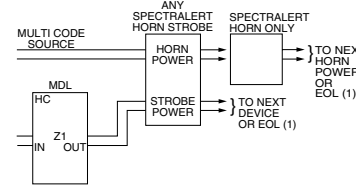

A0265-01

NOTE: Horn control must be powered for horn/strobes to operate the horn portion.

NOTE: SpectralAlert Advance horn-only/chime-only and horn/strobe or chime/strobe devices must be set to coded for multi-code sourcing.

**FIGURES 5 & 6. MOUNTING DIAGRAM:**

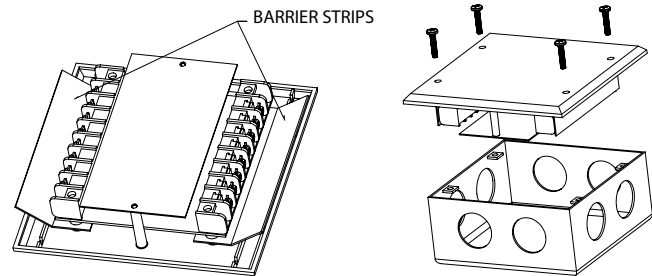

A0423-00

1. Fold barrier strip flat and complete field wiring. Input terminal wire gauge: 12 to 18 AWG.
2. Fold barrier strips toward terminal block and mount unit to back box with screws provided. Back box must be 4-11/16" x 4-11/16" x 2-1/8" deep.

**Please refer to insert for the Limitations of Fire Alarm Systems**



**THE LIMITATIONS OF SOUNDER/STROBES**

The sounder and/or strobe will not work without power. The sounder/strobe gets its power from the fire/security panel monitoring the alarm system. If power is cut off for any reason, the sounder/strobe will not provide the desired audio or visual warning.

The sounder may not be heard. The loudness of the sounder meets (or exceeds) current Underwriters Laboratories' standards. However, the sounder may not alert a sound sleeper or one who has recently used drugs or has been drinking alcoholic beverages. The sounder may not be heard if it is placed on a different floor from the person in hazard or if placed too far away to be heard over the ambient noise such as traffic, air conditioners, machinery or music appliances that may prevent alert persons from hearing the alarm. The sounder may not be heard by persons who are hearing impaired.

The signal strobe may not be seen. The electronic visual warning signal uses an extremely reliable xenon flash tube. It flashes at least once every three seconds and exceeds current Underwriters Laboratories standards for private mode viewing. The visual warning signal is suitable for direct view-

ing and must be installed within an area where it can be seen by building occupants. The strobe must not be installed in direct sunlight or areas of high light intensity (over 60 foot candles) where the visual flash might be disregarded or not seen. The strobe may not be seen by the visually impaired and is not intended to meet American Disabilities Act (ADA) requirements.

The signal strobe may cause seizures. Individuals who have positive photic response to visual stimuli with seizures, such as persons with epilepsy, should avoid prolonged exposure to environments in which strobe signals, including this strobe, are activated.

The signal strobe cannot operate from coded power supplies. Coded power supplies produce interrupted power. The strobe must have an uninterrupted source of dc power in order to operate correctly. System Sensor recommends that the sounder and signal strobe always be used in combination so that the risks from any of the above limitations are minimized.

**THREE-YEAR LIMITED WARRANTY**

System Sensor warrants its enclosed product to be free from defects in materials and workmanship under normal use and service for a period of three years from date of manufacture. System Sensor makes no other express warranty for the enclosed product. No agent, representative, dealer, or employee of the Company has the authority to increase or alter the obligations or limitations of this Warranty. The Company's obligation of this Warranty shall be limited to the replacement of any part of the product which is found to be defective in materials or workmanship under normal use and service during the three year period commencing with the date of manufacture. After phoning System Sensor's toll free number 800-SENSOR2 (736-7672) for a Return Authorization number, send defective units postage pre-paid to: System Sensor, Returns Department, RA # \_\_\_\_\_, 3825 Ohio Avenue, St. Charles, IL 60174.

Please include a note describing the malfunction and suspected cause of failure. The Company shall not be obligated to replace units which are found to be defective because of damage, unreasonable use, modifications, or alterations occurring after the date of manufacture. In no case shall the Company be liable for any consequential or incidental damages for breach of this or any other Warranty, expressed or implied whatsoever, even if the loss or damage is caused by the Company's negligence or fault. Some states do not allow the exclusion or limitation of incidental or consequential damages, so the above limitation or exclusion may not apply to you. This Warranty gives you specific legal rights, and you may also have other rights which vary from state to state.