



3825 Ohio Avenue , St. Charles, Illinois 60174
 1-800-SENSOR2, FAX: 630-377-6495
 www.systemsensor.com

B501B-FTX Detector Base

For use with the Filtrex™ Smoke Detector

Specifications

Base Diameter:	6.1 inches (155 mm)
Base Height	1.2 inches (31 mm)
Mounting:	4-inch square box with or without plaster ring, Min Depth - 1.5 inches (13 mm) 4-inch octagon box, Min. depth - 1.5 inches (13 mm) 3 ¹ / ₂ -inch octagon box, Min. depth - 1.5 inches (13 mm)
Operating Temperature Range:	0° to 49°C (32° to 120°F)
Operating Humidity Range:	10% to 93% Relative Humidity, noncondensing
Electrical Ratings	
Operating Voltage:	15 to 32 VDC
Currents:	
Detector-	230µA@24VDC (without communication) 285µA@24VDC (one communication every 5 seconds with LED enabled)
Air Intake-	6mA standby 60mA when checking for smoke (5 seconds on, 30 seconds off) 80mA when checking for proper airflow (15 seconds on, every 4 hours)

Before Installing

Please thoroughly read the system wiring and installation manuals, and manual I56-407, *Guide for Proper Use of System Smoke Detectors*, which provides detailed information on detector spacing, placement, zoning, and special applications. Copies of these manuals are available at no charge from System Sensor.

NOTICE: This manual should be left with the owner/user of this equipment.

IMPORTANT: The detector used with these bases must be tested and maintained regularly following NFPA 72 requirements. The detectors should be cleaned at least once a year.

Mounting

The detector base mounts directly to 3¹/₂- and 4-inch octagon and 4-inch square boxes, with or without a plaster ring.

To mount, remove the decorative ring by rotating it in either direction to unhook the snaps. Then, separate the ring from the base. Install the base on the box, using the screws supplied with the junction box and the appropriate slots in the base. Replace the decorative ring on the base and rotate it in either direction until the ring snaps in place (see Figure 1).

Installation Guidelines

All wiring must be installed in compliance with all applicable local codes and any special requirements of the local authority having jurisdiction, using the proper wire sizes. The conductors used to connect smoke detectors to control panels and accessory devices should be color-coded to reduce the likelihood of wiring errors. Improper connections can prevent a system from responding properly in the event of a fire.

For signal wiring (the wiring between interconnected detectors), it is recommended that the wire be no smaller than 18 gauge (1.0 square mm). However, wire sizes up to 12 gauge (3.3 square mm) can be used with the base. The use of twisted pair wiring or shielded cable for the power (+ and -) loop is recommended to minimize the effects of electrical interference.

If shielded cable is used, the shield connection to and from the detector must be continuous by using wire nuts, crimping, or soldering, as appropriate, for a reliable connection.

Alarm system control panels have specifications for allowable loop resistance. Consult the control panel specifications for the total loop resistance allowed before wiring the detector loops.

Please refer to insert for the Limitations of Fire Alarm Systems

Three-Year Limited Warranty

System Sensor warrants its enclosed smoke detector base to be free from defects in materials and workmanship under normal use and service for a period of three years from date of manufacture. System Sensor makes no other express warranty for this smoke detector base. No agent, representative, dealer, or employee of the Company has the authority to increase or alter the obligations or limitations of this Warranty. The Company's obligation of this Warranty shall be limited to the repair or replacement of any part of the smoke detector base which is found to be defective in materials or workmanship under normal use and service during the three year period commencing with the date of manufacture. After phoning System Sensor's toll free number 800-SENSOR2 (736-7672) for a Return Authorization number, send defective units postage prepaid to: System Sensor, Repair Department, RA # _____, 3825 Ohio Avenue, St.

Charles, IL 60174. Please include a note describing the malfunction and suspected cause of failure. The Company shall not be obligated to repair or replace units which are found to be defective because of damage, unreasonable use, modifications, or alterations occurring after the date of manufacture. In no case shall the Company be liable for any consequential or incidental damages for breach of this or any other Warranty, expressed or implied whatsoever, even if the loss or damage is caused by the Company's negligence or fault. Some states do not allow the exclusion or limitation of incidental or consequential damages, so the above limitation or exclusion may not apply to you. This Warranty gives you specific legal rights, and you may also have other rights which vary from state to state.

Figure 2. Wiring diagram:

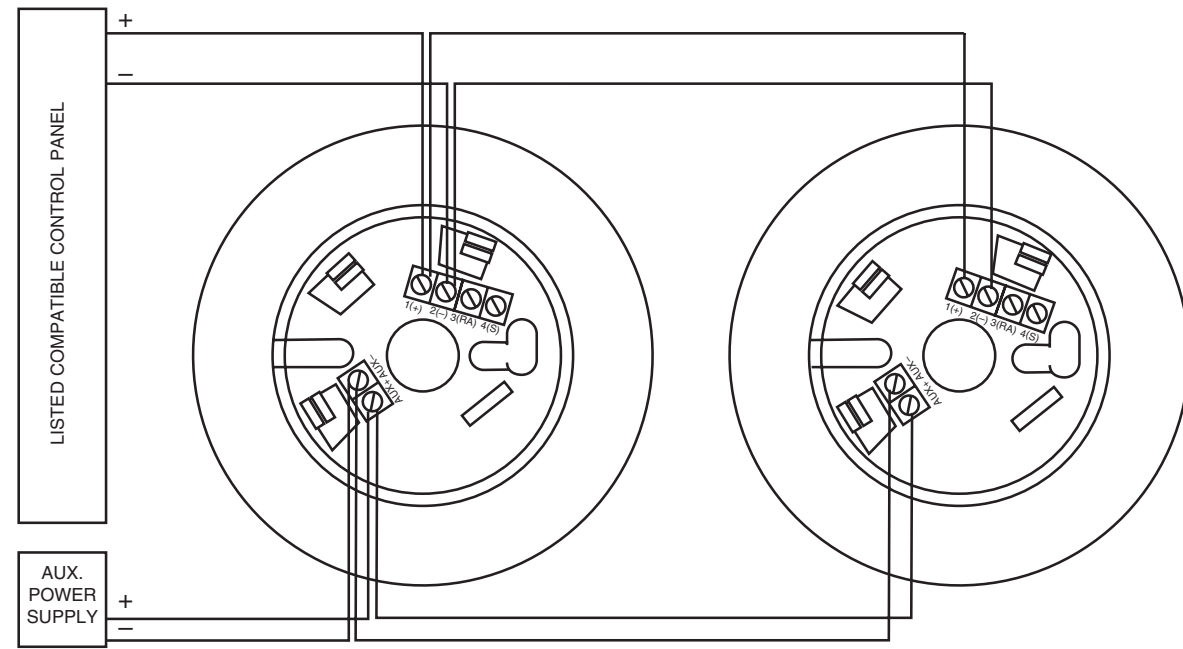

C0121-00

Figure 3A. Activating the tamper-resist feature:

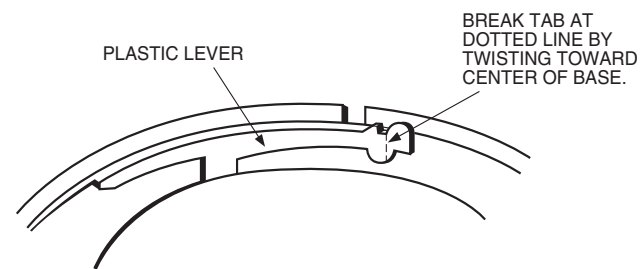
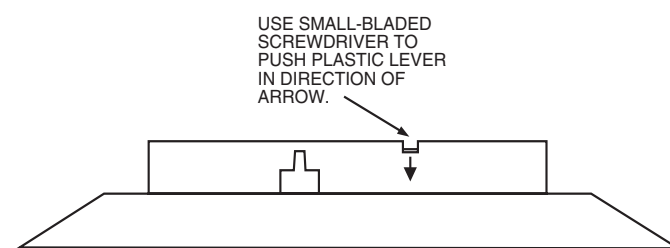

Figure 3B. Removing the detector head from the base:



C0130-00

Wiring Instructions

Make wiring connections by stripping about $\frac{3}{8}$ " (10 mm) of insulation from the end of the wire. Then, slide the wire under the clamping plate and tighten the clamping plate screw.

Wire the remote annunciator (RA) line to terminal 3 (see Figure 2). Wire the communication lines in (+) and out (+) to terminal 1. Insert the communication line in (-) and out (-) to terminal 2. Terminal 4 is for shielded cable only (see Figure 2). If shielded cable is used, the shield connection to and from the detector must be continuous by using wire nuts, crimping, or soldering to ensure a reliable connection. If shielded cable is not used, leave terminal 4 in the screwed-down position.

Wire the auxiliary power supply positive line to the AUX(+). Wire the auxiliary power supply return to the AUX(-).

Insert the 5-wire connector on the mounting base into the 5-pin connector located on bottom of the Filtrex unit. Check the zone wiring of all bases in the system before installing detector heads. This includes checking the wiring for continuity, correct polarity, ground fault testing, and performing a dielectric test.

A label is affixed to the base for recording the zone, address, and type of detector being installed at the base location. This information is useful for setting the detector head address and for verification of the sensor type required for that location.

Once all detector bases have been wired and mounted, and the loop wiring has been checked, the detector heads may be installed in the bases.

Tamper-resist Feature

This detector base includes a tamper-resist feature that prevents its removal from the base without the use of a tool. To activate this feature, break the tab from the detector base as shown in Figure 3A. Then, install the detector. To remove the detector from the base once the tamper-resist feature has been activated, insert a small-bladed screwdriver into the slot in the side of the base and push the plastic lever away from the detector head (see Figure 3B). This allows the detector to be rotated counterclockwise for removal.

Figure 1. Mounting the base to an electrical box:

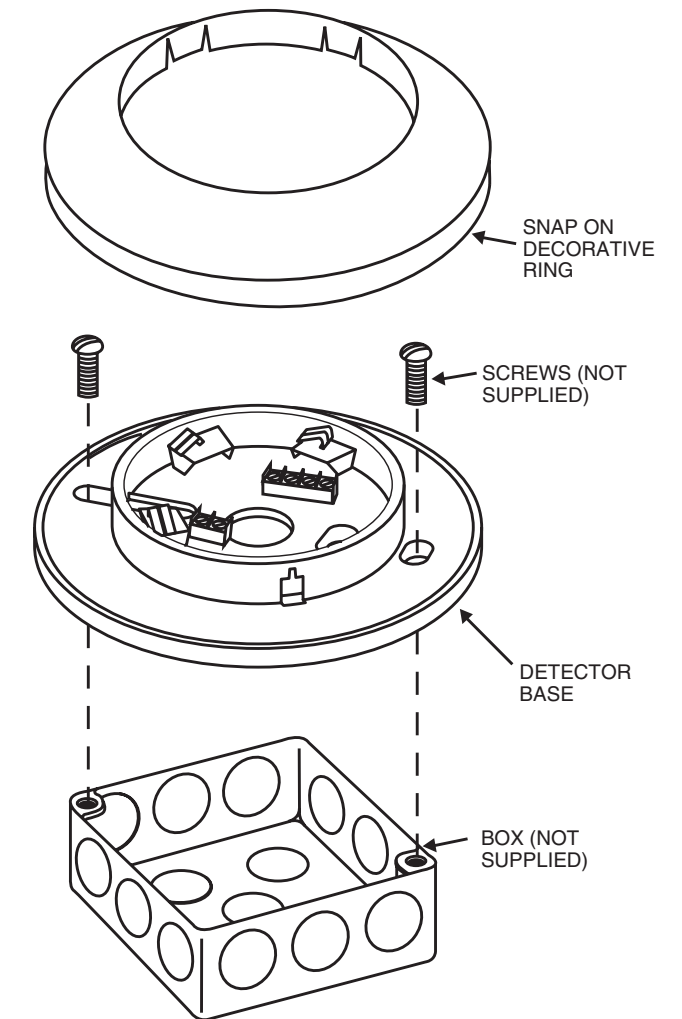

C0148-00

NOTE: Head removal after the tamper-resist feature has been activated first requires removal of the decorative ring. The tamper-resist feature can be defeated by breaking and removing the plastic lever from the base. However, this prevents the feature from being used again.