



3825 Ohio Avenue, St. Charles, Illinois 60174  
 1-800-SENSOR2, FAX: 630-377-6495  
 www.systemsensor.com

# DH500 Intelligent Air Duct Smoke Detector Housing

**Specifications**

Length:	14.5 inches (36.7 cm)
Width:	5 inches (12.7 cm)
Depth:	3.5 inches (8.9 cm)
Weight:	2.8 lbs. (1.1 kg)
Operating Temperature Range:	32° to 120°F (0° to 49°C)
Operating Humidity Range:	10% to 93% Relative Humidity
Duct Air Velocity:	500 – 4000 ft./min. (91.4 – 1219.2 m/min.)

**Electrical Ratings for DH500**

Voltage Range:	14.5 – 32 VDC Peak
Standby Current (nominal):	150uA at 24 VDC
Power-Up Surge at Max. Rated Voltage:	1.5mA-sec.
LED current (nominal):	6mA at 24 VDC

**Before Installing**

Please thoroughly read System Sensor’s *Guide for Proper Use of Smoke Detectors in Duct Applications (I56-473-XX)*, which provides detailed information on detector spacing, placement, zoning, wiring, and special applications. Copies of this manual are available from System Sensor. NFPA Standards 72 and 90A should also be referenced for detailed information.

**NOTICE:** This manual should be left with the owner/user of this equipment.

**IMPORTANT:** This detector must be tested and maintained regularly following NFPA 72 requirements. The detector should be cleaned at least once a year.

**General Description**

An HVAC system supplies conditioned air to virtually every area of a building. Smoke introduced into this air duct system will be distributed to the entire building. Smoke detectors designed for use in air duct systems are used to sense the presence of smoke in the duct.

The DH500 Air Duct Detector Housings are used with System Sensor’s intelligent model 1551 ionization detector head and model 2551 photoelectronic detector head. These two principal smoke detection methods are combined with an efficient housing design that samples air passing through a duct and allows early detection of a developing hazardous condition. When sufficient smoke is sensed, an alarm signal is initiated at the fire control panel monitoring the detector, and appropriate action can be taken to shut off fans and

blowers, change over air handling systems, etc. This can prevent the distribution or isolation of toxic smoke and fire gases throughout the areas served by the duct system.

Two LEDs on each detector latch ON to provide a local alarm indication. There is also a remote alarm output for use with auxiliary devices. The DH500 has remote test capability with the RTS451/RTS451KEY Remote Test Station.

**Contents of the Duct Detector Housing Kit**

The DH500 consists of the following items: (See Figure 1.)

See Note 1 on Page 2 for inlet sampling tube and detector supply information.

1. Complete housing base and cover assembly.
2. Two #10 sheet metal mounting screws.
3. Two sampling tube filters.
4. One test magnet.
5. Drilling template.
6. Two 5/16-inch O-rings.
7. Two rubber tube bushings seals.
8. Four #6 self-tapping mounting screws for the sampling tube.
9. One filter adapter.
10. One inlet tube end plug.
11. Four #6x7/10 cover mounting screws.
12. Two #10 speed nuts.
13. One test coil and parts bag.

**Figure 1:**

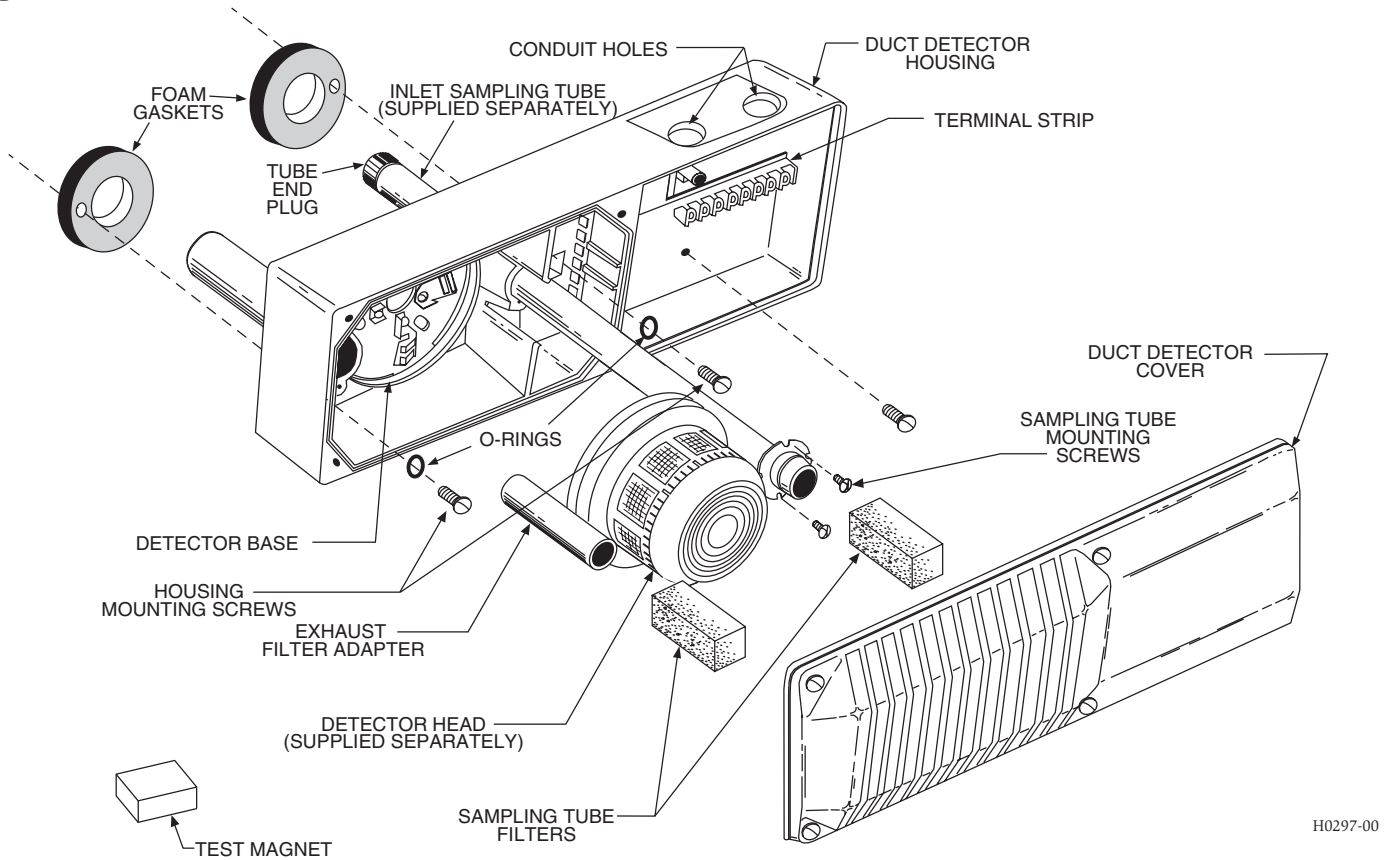

H0297-00

**NOTE:** The inlet sampling tube must be ordered separately. It must be the correct length for the width of the duct where it will be installed. See Table 1 to determine the inlet tube required for different duct widths. Smoke detector heads (1551, ionization; 2551, photoelectric) must be ordered separately.

**Installation Sequence**

	<b>Page</b>
Step 1. Verify duct air flow direction and velocity	2
Step 2. Drill the mounting holes	3
Step 3. Secure the housing base to the duct	3
Step 4. Install the inlet sampling tube	3
Step 5. Field wiring	5
Step 6. Install the filters and check pressure differential	5
Step 7. Perform detector check	7
Step 8. Install the cover	8
Step 9. Perform the final system check (Testing)	8

**Step 1. Verify Duct Air Flow Direction and Velocity**

The DH500 is designed to be used in air handling systems having air velocities of 500 to 4000 feet per minute. Be sure to check engineering specifications to ensure that the air velocity in the duct falls within these parameters. If necessary, an Alnor Model 6000-P velocity meter, Dwyer 460 differential pressure gauge, or their equivalent, may be used to check the air velocity in the duct.

**Step 2. Drill the Mounting Holes**

Remove the paper backing from the top and bottom of the template. Affix the template to the air duct at the desired mounting location. Make sure the template lies flat and smooth on the air duct. Center punch hole targets and remove the template. Drill the holes as indicated on the template. Slide the two speed nuts over the two small holes (Hole A) next to the sampling tube bushing holes (Hole B) previously drilled in the duct. (See Figure 2.)

**Step 3. Mount Duct Housing**

Remove the duct housing cover. Slide the foam gaskets over the tube bushings as shown in Figure 2B. Make sure the two small holes in the gaskets line up with the two base mounting holes. Put one 5/16-inch O-ring over each of the two #10 sheet metal screws. Use the two sheet metal screws to secure the duct housing to the duct.

**CAUTION**

Do not overtighten the screws.

**Figure 2A. Speed nut mounting location:**

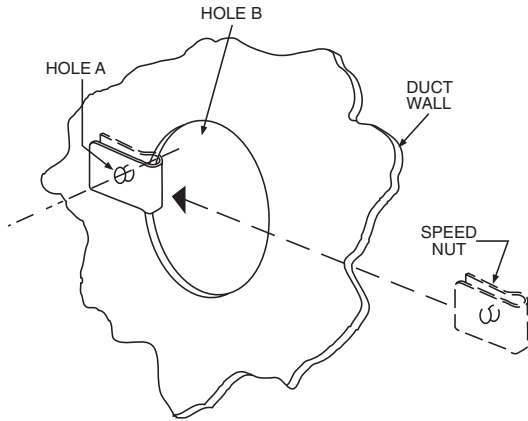

**Figure 2B. Installation of foam gaskets over sampling tube bushings:**

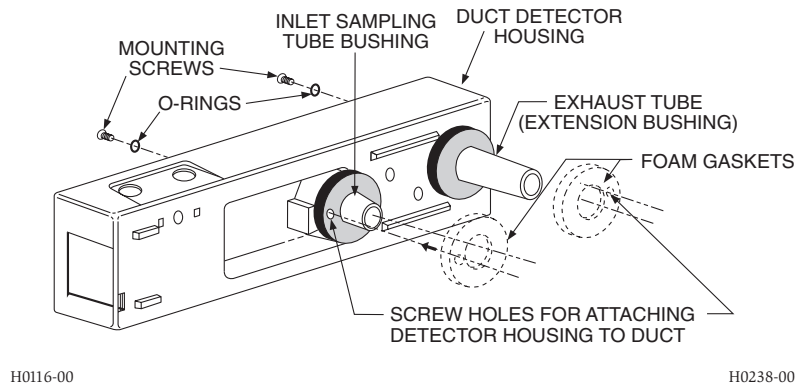

**Table 1. Sampling (Inlet) Tubes**

Tube	Outside Duct Width	
ST-1.5	1 to 2 ft.	(0.3 to 0.6 m)
ST-3	2 to 4 ft.	(0.6 to 1.2 m)
ST-5	4 to 8 ft.	(1.2 to 2.4 m)
ST-10	8 to 12 ft.	(2.4 to 3.7 m)

**Step 4. Install the Inlet Tube**

The inlet tube (shown in Figure 3) is identified by a series

**Figure 3. Air duct detector inlet sampling tube:**

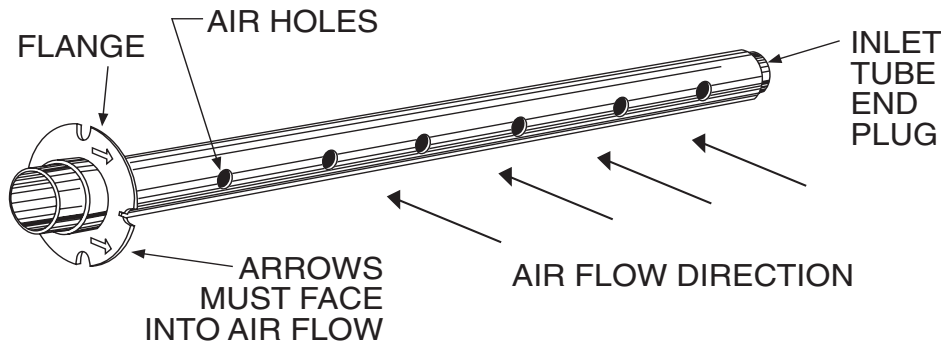

of air inlet holes on the tube. This tube must be purchased separately. Order the correct length, as specified in Table 1, for the width of the duct where it will be installed. The exhaust tube is molded into the base of the duct housing.

The inlet tube is always installed in the right house bushing, with the air inlet holes facing into the air flow. To assure proper installation, the tube mounting flange is marked with arrows. Mount the inlet tube so that the arrows point into the air flow. Figure 4 shows the various combinations of tube mounting configurations with respect to air flow.

**A. Installation for Ducts Less Than 8 Feet Wide**

1. If the inlet tube is longer than the width of the air duct, drill a 3/4-inch hole in the duct directly opposite the hole already cut for the inlet tube.  
If the inlet tube is shorter than the width of the air duct, install the end cap into the inlet tube (see Figure 3).
2. Slide the inlet tube into the right housing bushing. Position the tube so that the arrows point into the air flow.
3. Secure the tube flange to the housing bushing with the two #6 self-tapping screws.
4. For tubes longer than the width of the air duct, the tube should extend out of the opposite side of the duct. If

there are more than 2 holes in the section of the tube extending out of the duct, select a different tube length using Table 1. Otherwise, trim the end of the tube protruding through the duct so that 1 to 2 inches of the tube extends outside the duct. Plug this end with the tube end plug and tape closed any holes in the protruding section of the tube. Be sure to seal the duct when the tube protrudes.

5. Any inlet tube over 3 feet long must be supported on the opposite side of the duct detector housing.

**Figure 4. Tube mounting configurations with varying air flow direction and orientation of detector housing. Vertical as well as horizontal mounting is acceptable.**

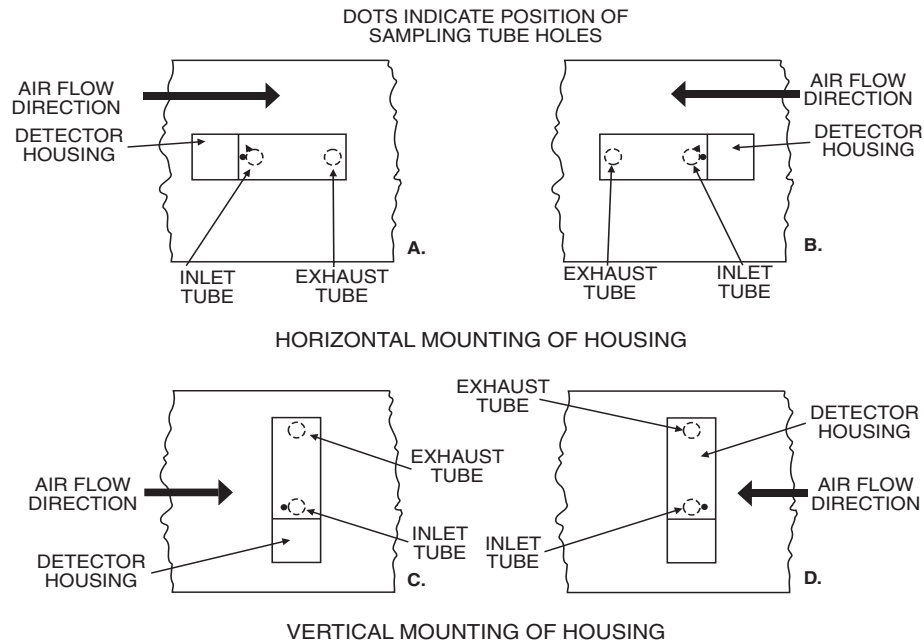

H0109-00

**▲WARNING**

In no case should more than 2 air inlet holes be cut off the tube. There must be a minimum of 10 holes in the tube exposed to the air stream.

**B. Installation for Ducts More Than 8 Feet Wide**

**NOTE:** To install inlet tubes in ducts more than 8 feet wide, work must be performed inside the air duct. Sampling of air in ducts wider than 8 feet is accomplished by using the ST-10 inlet sampling tube.

Install the inlet tube as follows:

1. Drill a 3/4-inch hole in the duct directly opposite the hole already drilled for the inlet tube.
2. Slide the inlet tube with the flange into the right housing bushing. Position the tube so that the arrows point into the air flow. Secure the tube flange to the housing bushing with the two #6 self-tapping screws.
3. From inside the duct, couple the other section of the inlet tube to the section already installed using the 1/2-inch conduit fitting supplied. Make sure the holes on both of the air inlet tubes are lined up facing the air flow.
4. Trim the end of the tube protruding through the duct so that 1 to 2 inches of the tube extends outside the duct. Plug this end with the tube end cap and tape closed any holes in the protruding section of the tube. Be sure to seal the duct when the tube protrudes.
5. Any tube (over 3 feet long) that doesn't protrude through the duct (on the side opposite the housing) must be supported by other means.

**NOTE:** An alternate method to using the ST-10 is to use two ST-5 inlet tubes. Remove the flange from one of the tubes and install as described above. After the installation, use electrician's tape to close off some of the sampling holes so that there are a total of 12 holes spaced as evenly as possible across the width of the duct.

**NOTE:** Air currents inside the duct may cause excessive vibration. This vibration can slowly open the seal around the tube and permit air to escape. To prevent this from occurring, a 3-inch floor flange, available at most plumbing supply houses, may be used. This flange/connector mounting technique makes the initial installation easier because a 1-inch to 1-1/4-inch hole may be drilled where the flange/connector will be used. It is easier to push the inlet tube through the larger hole.

**Modification of Inlet Sampling Tubes**

There may be applications where duct widths are not what is specified for the installation. In such cases, it is permissible to modify an inlet sampling tube that is longer than necessary to span the duct width.

Use a 0.193-inch diameter (#11) drill and add the appropriate number of holes so that the total number of holes exposed to the air flow in the duct is 10 to 12. Space the additional holes as evenly as possible over the length of the tube.

**NOTE:** This procedure should only be used in an emergency, and it is not intended as a permanent substitute for ordering the correct length tubes.

### Step 5. Field Wiring

#### Wiring Installation Guidelines

All wiring must be installed in compliance with the Canadian Electrical Code and the local codes having jurisdiction. Proper wire gauges should be used. The conductors used to connect smoke detectors to control panels and accessory devices should be color-coded to prevent wiring mistakes. Improper connections can prevent a system from responding properly in the event of a fire.

For signal wiring, (the wiring between interconnected detectors or from detectors to auxiliary devices), it is recommended that single-conductor wire be no smaller than 16 gauge (1.5 square mm), and that two- or three-conductor wire be no smaller than 18 gauge (1.0 square mm). The last foot or so of conduit should be flexible steel conduit (available in electrical supply houses) which facilitates easier installation and puts less strain on the conduit holes in the housing. Solid conduit connections may be used if desired.

Smoke detectors and alarm system control panels have specifications for allowable loop resistance. Consult the control panel manufacturer's specifications for the total loop resistance allowed for the particular model control panel being used before wiring the detector loop.

#### Wiring Instructions

The DH500 is designed for easy wiring. The housing provides a terminal strip with clamping plates. Wiring connections are made by stripping approximately 1/2-inch of insulation from the end of the wire, sliding this bare end under the plate, and tightening the clamping plate screw.

### Step 6. Install the Filters

Most duct installations are subject to dust accumulation. System filters remove a large percentage of this contamination, but cannot remove all of it. Dust inside the duct detector causes problems. First, very fine particles of dust can enter the detector sensing chamber and cause the unit to go into alarm. Second, the accumulation of dust and dirt necessitates a more frequent periodic cleaning schedule, which can result in substantial cost and/or down time.

Disposable sampling tube filters can greatly reduce the nuisance alarms caused by dust, and can also significantly extend the maintenance interval. To install the sampling tube filters, simply push the filter adapter into the exhaust tube, and then push the filter onto the adapter tube on the

left, as shown in Figure 6. Then install the other filter over the end of the inlet sampling tube.

#### CAUTION

Filters require periodic cleaning or replacement, depending on the amount of dust and dirt accumulated. Visually inspect the filters at least quarterly; inspect them more often if the dust accumulation warrants it. Replacement filters can be ordered from System Sensor (exhaust tube/intake tube filter P/N F36-05-00).

The filters do not substantially affect smoke performance under normal conditions. There is very little restriction of smoke entry even when up to 90% of the filter is clogged. Visual inspection is usually adequate to determine whether the filters should be replaced because such a high percentage of contamination is required to affect performance.

However, if further testing is desired, a Dwyer Model 460 (or equivalent) Differential Pressure Gauge may be used. Simply compare the differential pressure readings with and without the filters attached. There should be little or no difference. If the difference exceeds 10%, replace the filters. In no case, however, should the pressure differential be less than 0.01 inches of water or greater than 1.2 inches of water.

### Step 7. Perform Detector Check

#### 7.1 Air Flow

1. To verify sufficient sampling of ducted air, use a manometer to measure the differential pressure created from air flow across the sampling tubes. The pressure should measure no less than 0.01 inches of water and no greater than 1.20 inches of water.

**Figure 6. Sampling tube filter installation:**

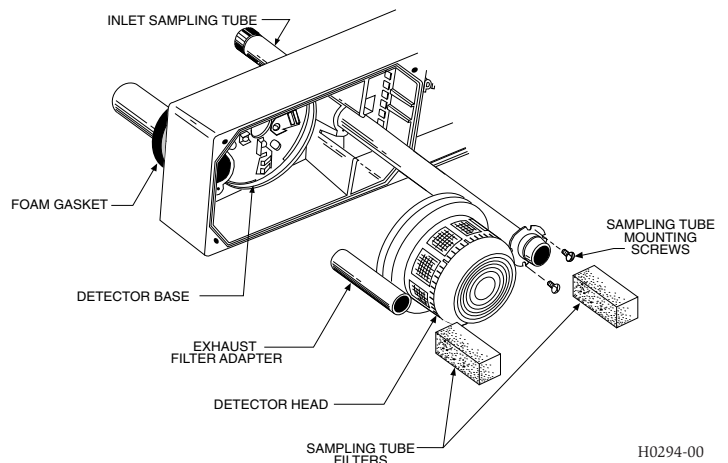

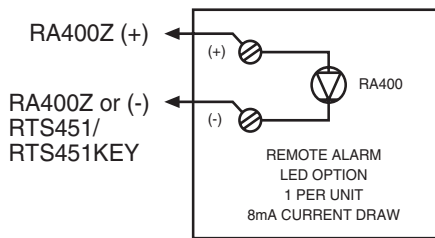

Figure 5A.

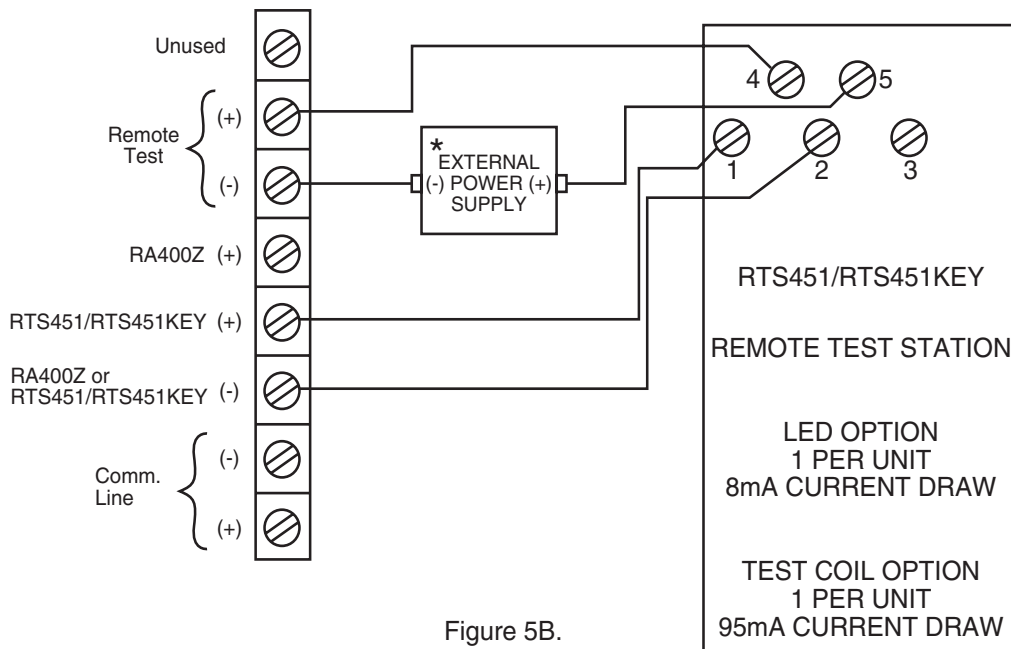

Figure 5B.

\* The RTS451/RTS451KEY test coil circuit requires an external 24VDC power supply which must be UL listed

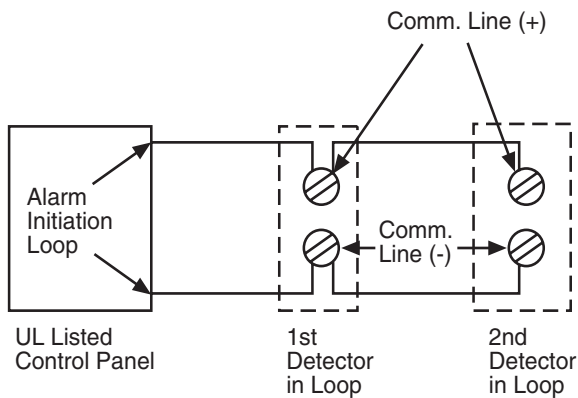

Figure 5C. System wiring diagram for duct detectors using a UL listed control panel.

H0295-00

2. To determine that smoke is capable of entering the sensing chamber, a visual examination should be conducted to note any obscurations around the sensing chamber. If a smoke test is required, smoke such as cigarette, cotton wick, or punk smoke may be blown directly at the smoke detector head. It is important to plug the exhaust and sampling tube hole to prevent ducted air from blowing smoke away from the smoke detector head. Record all test records in the Detector Test Log (page 12).

**CAUTION**

Remember to remove the plugs after this test or the detector will not sense smoke in the air duct.

### 7.2 Alarm Tests

Before replacing the duct housing cover, the detector interconnections should be checked. The DH500 may be checked as follows:

#### A. M02-04-00 Magnet Test

1. Make sure power is applied to the detector.
2. Place the painted surface of the test magnet against the housing next to the rib molded onto the outside of the housing (see Figure 7).
3. The LEDs on the detector should latch on as should any accessories (i.e. RA400ZA, RTS451), and the alarm condition should be verified at the control panel.

**Figure 7. Testing detector**

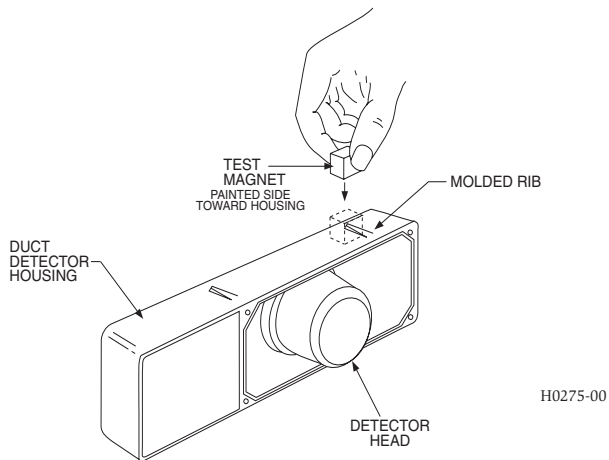

**Figure 8. Detector head removal:**

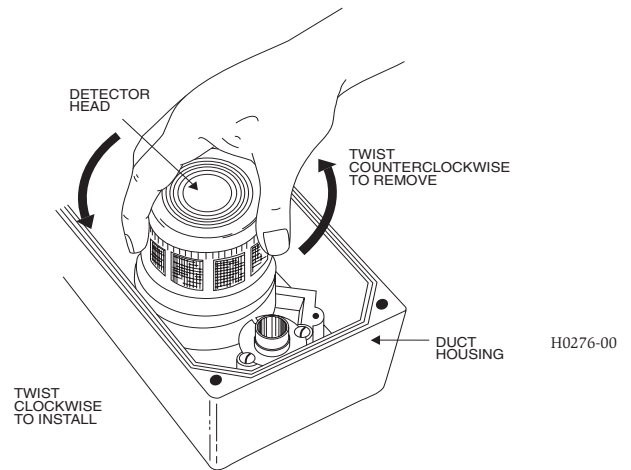

#### B. RTS451/RTS451KEY Remote Test Station

The RTS451/RTS451KEY Remote Test Station facilitates test of the alarm capability of the duct detector as indicated in the RTS451/RTS451KEY manual. The DH500 duct detector cannot be reset by the RTS451/RTS451KEY. It must be reset at the system control panel.

To install the RTS451/RTS451KEY test coil, connect the device as shown in Figure 9; wire runs must be limited to 25 ohms or less per interconnecting wire. Place the coil in the detector housing with the arrow facing up and pointing toward the detector as in Figure 9. Attach the coil leads to the housing terminals as shown; polarity is not important. Firmly screw the bracket in place over the test coil.

### 7.3 MOD400 Sensitivity Test

After verification of alarm capability, the MOD400 test module may be used with a voltmeter to check detector sensitivity as indicated in the MOD400 installation manual. The housing cover must be removed to perform this test.

If the MOD400 readings indicate that the detector head is outside of the acceptable range, the detector head requires cleaning. (See Periodic Maintenance Requirements on page 9.)

### 7.4 Trouble Test

The capability of “TROUBLE” detection is tested by removing the detector head from the duct housing. The detector head is removed by turning it counterclockwise about 10 degrees (Figure 8). The system control panel should indicate a trouble condition. Reinserting the detector head should clear the trouble condition.

**Figure 9. RTS451/RTS451KEY test coil installation:**

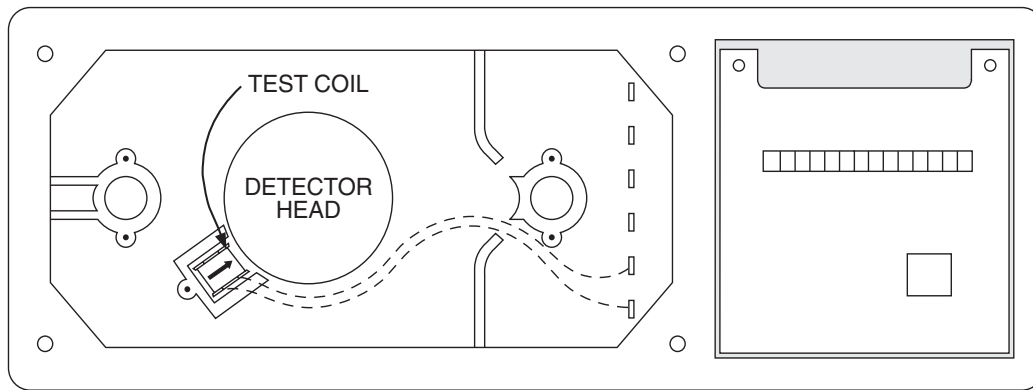

H0292-00

### Step 8. Install the Cover

Install the cover using the four screws. Be certain filters are installed as specified in Step 6. Make sure that the cover fits into the base groove and that all gaskets are in their proper positions. Tighten the four cover screws to 10 in/lbs.

### Step 9. Perform the Final System Check

Place the magnet in position as shown in Figure 7. The LEDs on the detector should light. Any accessory LED(s) will also light. The system control panel should indicate an alarm condition.

### Periodic Maintenance Requirements

Air duct smoke detectors should be maintained at least once a year. They should be maintained more often if the detector heads become obviously dirty in less than a year. The detectors must also be cleaned immediately after a fire. Failure to properly maintain air duct smoke detectors may cause unnecessary false alarms.

It is recommended that a permanent Detector Test Log be set up and maintained, with a record for each individual smoke detector in each building. Each detector should be clearly described, with information on the type of detector, the model number, the serial number (if any), the location, and the type of environment. Data entries should include test dates, type of test mode, test results, maintenance, and comments. A detector test log is included in this manual.

### Recommended Detector Maintenance Procedure

**NOTE:** Notify the proper authorities that the smoke detector system is undergoing maintenance, and therefore the system will temporarily be out of service. Disable the zone or system undergoing maintenance to prevent unwanted alarms and possible dispatch of the fire department.

1. Turn off power to the system.
2. Remove and inspect sampling tube filters.
3. If filters are heavily coated with dirt, replace them with

new filters. If they are not heavily coated, use a vacuum cleaner or compressed air nozzle to remove dust, then reinstall the filters.

4. Remove detector from housing. (See Figure 8.)

### Photo Units

5. Remove detector cover by inserting a small blade screwdriver into the slot located 90 degrees from the MOD400 test jack receptacle, twisting the cover counterclockwise to remove (see Figure 10).
6. Lift screen from photo chamber. Vacuum screen and cover before using clean, compressed air to loosen and blow out any remaining debris. (Replacement screens are available, part no. RS24.)
7. Vacuum photo chamber, then use clean compressed air to blow area clean.
8. Replace screen by aligning arrow on top with the field test slot on the base of the detector. Push screen into place. Screen should fit tightly to chamber.

### Ionization Units

9. Remove the detector cover and screen assembly by depressing the three lock prongs on the top of the cover and rotating the cover counterclockwise. The CRT400 Cover Removal Tool makes cover removal easier. (See Figure 11.)
10. Carefully pull the screen out of the cover.
11. Clean the screen thoroughly with a soft brush or vacuum (replacement screen available, part no. RS14).
12. Brush or vacuum the inside of the cover. Cover may then be blown out using clean, compressed air. **DO NOT APPLY WATER TO THIS AREA.**
13. Vacuum the sensing chamber before using clean, compressed air to loosen and blow out any remaining debris. **DO NOT APPLY WATER TO THIS AREA.**
14. Press the screen back into the cover.
15. Replace the detector cover and screen assembly on the sensing chamber. Rotate it clockwise to lock it into place.



**Both Types Of Units**

16. Reinstall the detector housing.
17. Restore power to the system.
18. Put detector into alarm using appropriate method described in STEP 7. PERFORM DETECTOR CHECK (page 7 of this manual).
19. Notify the proper authorities that testing has been completed and the smoke detector system is again operational.
20. Other checks that should be made during maintenance procedures:
  - Holes or cracks in duct work near vicinity of detector
  - Air leaks where detector housing or sampling tubes are attached to duct
  - Dust accumulations in or on sampling tubes
  - Wiring terminal screw tightness

Ionization Replacement Screen	RS14
Sensitivity Test Kit	MOD400
Ionization Cover Removal Tool	CRT400

**Programming Specifications/Requirements for Intelligent System Control Panels**

**CAUTION**

The 1551 and 2551 models can be used with the DH500 if the following constraints are observed.

There is a limit to the number of devices per zone that can have their LEDs latched ON. The actual number of devices is determined by the control panel and its ability to supply LED current. Refer to the equipment manual supplied by the control panel manufacturer for details.

**Accessories**

Accessories	Part No.
Remote LED	RA400ZA
Remote Test Station	RTS451/RTS451KEY
Piezo Alert Sounder	PA400
Replacement Filters	F36-05-00
Magnet	M02-04-00
End Plug For Sampling Tube	P48-21-00
Installation Kit (Parts bag)	A2650-01

**Figure 10. Photo head exploded view:**

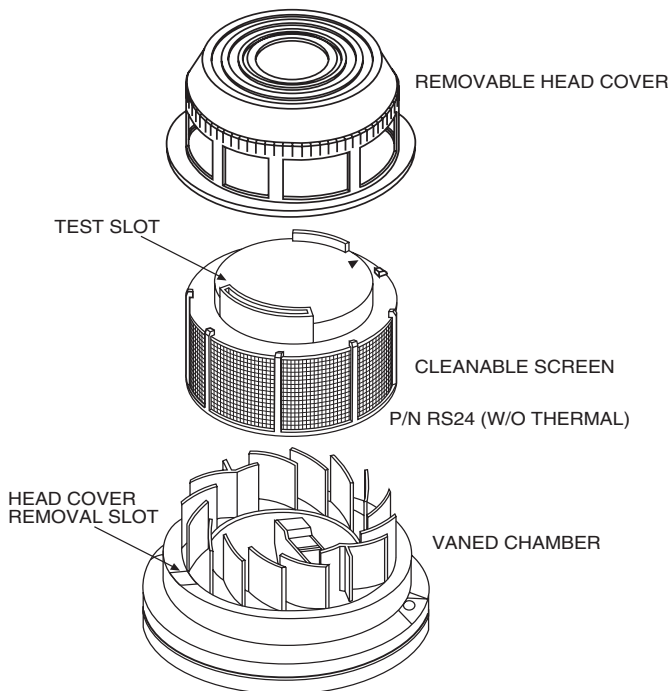

H0261-00

**Figure 11. Ion head exploded view:**

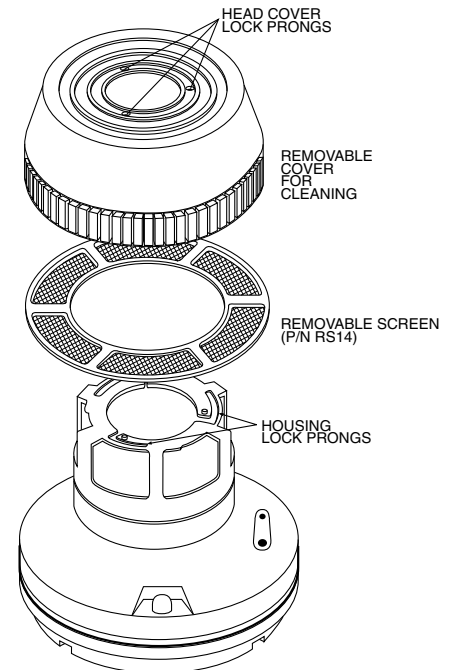

H0296-00



**Please refer to insert for the Limitations of Fire Alarm Systems**

**Three-Year Limited Warranty**

System Sensor warrants its enclosed smoke detector to be free from defects in materials and workmanship under normal use and service for a period of three years from date of manufacture. System Sensor makes no other express warranty for this smoke detector. No agent, representative, dealer, or employee of the Company has the authority to increase or alter the obligations or limitations of this Warranty. The Company's obligation of this Warranty shall be limited to the repair or replacement of any part of the smoke detector which is found to be defective in materials or workmanship under normal use and service during the three year period commencing with the date of manufacture. After phoning System Sensor's toll free number 800-SENSOR2 (736-7672) for a Return Authorization number, send defective units postage prepaid to: System Sensor, Repair

Department, RA # \_\_\_\_\_, 3825 Ohio Avenue, St. Charles, IL 60174. Please include a note describing the malfunction and suspected cause of failure. The Company shall not be obligated to repair or replace units which are found to be defective because of damage, unreasonable use, modifications, or alterations occurring after the date of manufacture. In no case shall the Company be liable for any consequential or incidental damages for breach of this or any other Warranty, expressed or implied whatsoever, even if the loss or damage is caused by the Company's negligence or fault. Some states do not allow the exclusion or limitation of incidental or consequential damages, so the above limitation or exclusion may not apply to you. This Warranty gives you specific legal rights, and you may also have other rights which vary from state to state.

