

INSTALLATION AND MAINTENANCE INSTRUCTIONS



3825 Ohio Avenue, St. Charles, Illinois 60174
1-800-SENSOR2, FAX: 630-377-6495
www.systemsensor.com

156-594-03R

B110LP Plug-in Detector Base

For use with the following smoke detectors:

IN US: 1151, 2151
IN CANADA: 1151A, 2151A
IN EUROPE: 1151E, 2151E

Specifications

Base Diameter: 6.2 inches (157 mm)
Base Height: 0.95 inches (24 mm)
Weight: 0.3 lb. (137 g)
Mounting: 4-inch square box with or without plaster ring. Min. depth-1.5 inches
3-1/2-inch octagon box. Min. depth-1.5 inches

Operating Temperature Range: 0° to 49°C (32° to 120°F)
Operating Humidity Range: 10% to 93% Relative Humidity, Noncondensing

Electrical Ratings - includes base and detector

System Voltage: 12/24 VDC
Maximum Ripple Voltage: 4 Volts peak-to-peak
Start-up Capacitance: 0.02 µF Maximum
Standby Ratings: 8.5 VDC Minimum
35 VDC Maximum
120 µA Maximum

Alarm Ratings: 4.2 VDC Minimum at 10 mA
6.6 VDC Maximum at 100 mA
(Alarm current must be limited to 100 mA (130 mA for models 1151 and 2151) by the control panel. If it is used, the RA400Z Remote Annunciator operates within the specified detector alarm currents.)

Reset Voltage: 2.5 VDC Minimum
Reset Time: 0.3 Seconds Minimum
Start-up Time: 34.0 Seconds Maximum

Before Installing

Please thoroughly read the System Sensor manual I56-407, *Guide for Proper Use of System Smoke Detectors*, which provides detailed information on detector spacing, placement, zoning, wiring, and special applications. Copies of this manual are available at no charge from System Sensor. (For installation in Canada, please refer to CAN/ULC-S524, *Standard for the Installation of Fire Alarm Systems* and CEC Part 1, Sec. 32.)

NOTICE: This manual should be left with the owner/user of this equipment.

IMPORTANT: The detector used with this base must be tested and maintained regularly following NFPA 72 requirements. The detector used with this base should be cleaned at least once a year.

General Description

The Model B110LP detector base is designed for use with System Sensor models 2151 photoelectric and 1151 ionization detector heads. This two-wire base is equipped with screw terminals for the connection of power, ground, and an optional remote annunciator.

Mounting

The detector base mounts directly to 3-1/2 inch and 4-inch octagon boxes and 4-inch square boxes, with or without plaster rings. To mount the base, remove the decorative ring by rotating it in either direction to unhook the snaps before separating the ring from the base. Use the screws supplied with the junction box to attach the base to the box through the appropriate slots in the base (see Figure 1). Position the decorative ring around the base and rotate it in either direction until the ring snaps into place.



The Limitations of Property Protection Smoke Detectors

The smoke detector used with this base is designed to **activate and initiate** emergency action, but will do so only when it is used in conjunction with an authorized fire alarm system. This detector must be installed in accordance with NFPA standard 72.

Smoke detectors will not work without power. AC or DC powered smoke detectors will not work if the power supply is cut off.

Smoke detectors will not sense fires which start where smoke does not reach the detectors. Smoldering fires typically do not generate a lot of heat which is needed to drive the smoke up to the ceiling where the smoke detector is usually located. For this reason, there may be large delays in detecting a smoldering fire with either an ionization type detector or a photoelectric type detector. Either one of them may alarm only after flaming has initiated which will generate the heat needed to drive the smoke to the ceiling.

Smoke from fires in chimneys, in walls, on roofs or on the other side of a closed door(s) may not reach the smoke detector and alarm it. A detector cannot detect a fire developing on another level of a building quickly or at all. For these reasons, detectors **shall be located on every level and in every bedroom within a building.**

Smoke detectors have sensing limitations, too. Ionization detectors and photoelectric detectors are required to pass fire tests of the flaming

and smoldering type. This is to ensure that both can detect a wide range of types of fires. Ionization detectors offer a broad range of fire sensing capability but they are somewhat better at detecting fast flaming fires than slow smoldering fires. Photoelectric detectors sense smoldering fires better than flaming fires which have little, if any, visible smoke. Because fires develop in different ways and are often unpredictable in their growth, neither type of detector is always best, and a given detector may not always provide early warning of a specific type of fire.

In general, detectors cannot be expected to provide warnings for fires resulting from inadequate fire protection practices, violent explosions, escaping gases which ignite, improper storage of flammable liquids like cleaning solvents which ignite, other similar safety hazards, arson, smoking in bed, children playing with matches or lighters, etc. Smoke detectors used in high air velocity conditions may have a delay in alarm due to dilution of smoke densities created by frequent and rapid air exchanges. Additionally, high air velocity environments may create increased dust contamination, demanding more frequent maintenance.

Smoke detectors cannot last forever. Smoke detectors contain electronic parts. Even though smoke detectors are made to last over 10 years, any part can fail at any time. Therefore, smoke detectors shall be replaced after being in service for 10 years. The smoke detector system that this detector is used in must be tested regularly per NFPA 72. This smoke detector should be cleaned regularly per NFPA 72 or at least once a year.

Three-Year Limited Warranty

System Sensor warrants its enclosed smoke detector base to be free from defects in materials and workmanship under normal use and service for a period of three years from date of manufacture. System Sensor makes no other express warranty for this smoke detector base. No agent, representative, dealer, or employee of the Company has the authority to increase or alter the obligations or limitations of this Warranty. The Company's obligation of this Warranty shall be limited to the repair or replacement of any part of the smoke detector base which is found to be defective in materials or workmanship under normal use and service during the three year period commencing with the date of manufacture. After phoning System Sensor's toll free number 800-SENSOR2 (736-7672) for a Return Authorization number, send defective units postage prepaid to: System Sensor, Repair Department, RA #_____, 3825 Ohio Avenue, St.

Charles, IL 60174. Please include a note describing the malfunction and suspected cause of failure. The Company shall not be obligated to repair or replace units which are found to be defective because of damage, unreasonable use, modifications, or alterations occurring after the date of manufacture. In no case shall the Company be liable for any consequential or incidental damages for breach of this or any other Warranty, expressed or implied whatsoever, even if the loss or damage is caused by the Company's negligence or fault. Some states do not allow the exclusion or limitation of incidental or consequential damages, so the above limitation or exclusion may not apply to you. This Warranty gives you specific legal rights, and you may also have other rights which vary from state to state.

Installation Guidelines

Allowable loop resistance is an important specification for control panels as well as for smoke detectors and their bases. The alarm system cannot be expected to operate correctly if system components have incompatible allowable loop resistances. Therefore, before beginning installation, refer to the control panel manufacturer's loop resistance specification to ensure that it is listed as compatible with the System Sensor base and smoke detector being installed.

System Sensor smoke detectors and mounting bases are marked with a compatibility identifier as the last digit of a five-digit code stamped on the back of the product. Connect detectors only to compatible control units as indicated in System Sensor's compatibility chart. This chart consists of a current list of UL-listed control unit/detector combinations and is available from System Sensor upon request.

All wiring must be installed in compliance with the National Electrical Code and all applicable local codes and any special requirements of the authority having jurisdiction, using the proper wire size. The conductors used to connect smoke detectors to control panels and accessory devices should be color-coded to reduce the likelihood of wiring errors. Improper connections can prevent a system from responding properly in the event of a fire.

For signal wiring (the wiring between interconnected detectors), it is recommended that the wire be no smaller than AWG 18. However, the screws and clamping plate in the base can accommodate wire sizes up to AWG 12. The use of twisted pair wiring for the power (+ and -) loop is recommended to minimize the effects of electrical interference.

NOTE: To ensure that electrical connections are supervised, do NOT loop wires under terminals 2, 3, and 5 - break the wire at each terminal.

To make electrical connections, strip approximately 3/8" (1 cm) insulation from the end of each wire. Slide the wires under the clamp plate and tighten the terminal screw.

Check the zone wiring before installing the smoke detector head. The built-in shorting spring makes it convenient to do this. After the detector base is wired and attached to the electrical box, position the shorting spring against terminal 3. Use the slot in the retaining clip to hold the spring against the terminal, as shown in Figure 1. This shorts the negative-in and negative-out leads so that loop wiring can be tested for continuity.

Figure 1. Mounting base to box:

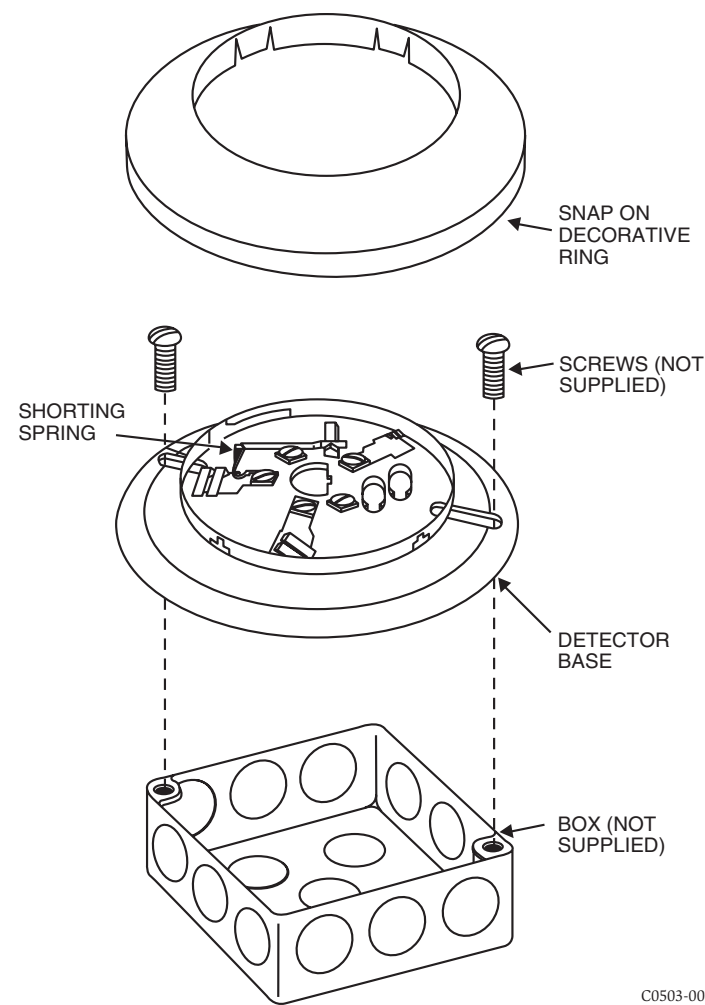

C0503-00

The shorting spring in the base will disengage automatically when the detector head is removed from the base. DO NOT remove the shorting spring since it reengages as the detector head is turned into the base, completing the circuit.

Tamper-resistance Feature

NOTE: DO NOT use the tamper-resistance feature if the System Sensor XR2 Removal Tool will be used to remove detectors from the base.

This detector base can be made tamper resistant so that the detector cannot be detached without the use of a tool. To make the base tamper-resistant, break off the smaller tab at the scribed line on the tamper-resistance tab, on the detector mounting bracket (see Figure 3A), before installing the detector.

Figure 2. Wiring diagram for a typical 2-wire detector system:

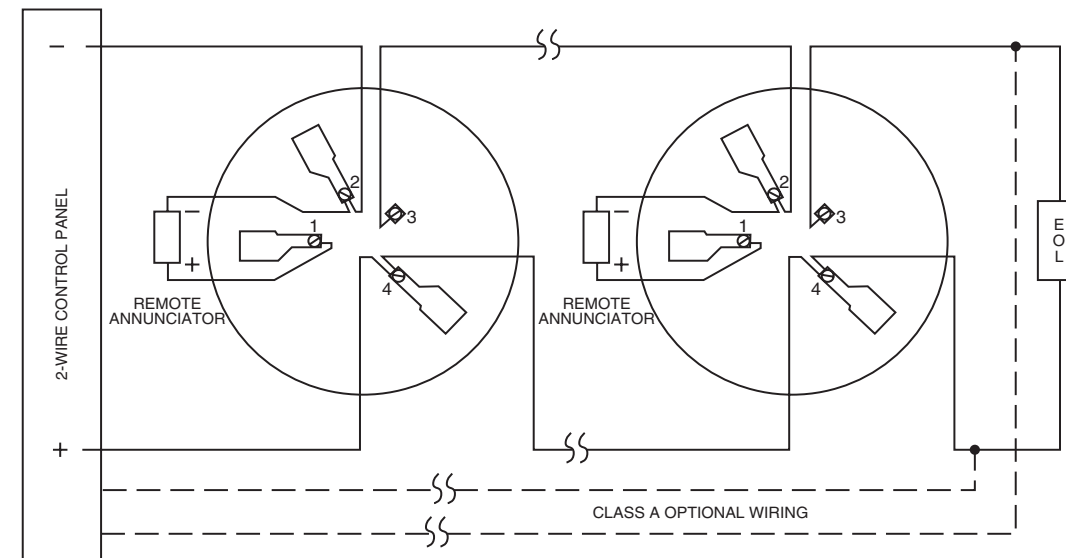

C0529-00

NOTE: IF A REMOTE ANNUNCIATOR IS NOT USED, POLARITY OF THESE TERMINALS MAY BE REVERSED.

To remove the detector from the base after it has been made tamper resistant, remove the decorative ring by rotating it in either direction and pulling it away from the base.

3B), and press the plastic lever toward the mounting surface before rotating the detector counterclockwise for removal.

Then, insert a small screwdriver into the notch (see Figure

Figure 3A. Activating the tamper-resistance feature:

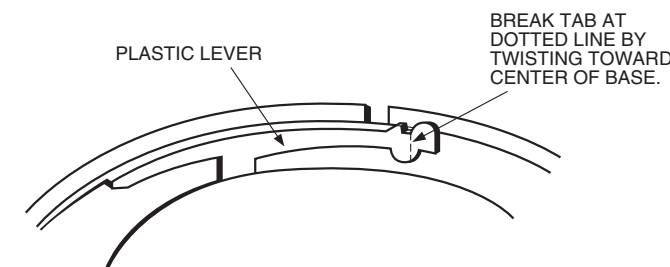
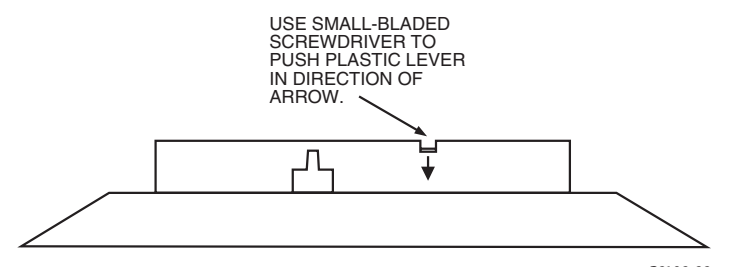

Figure 3B. Removing detector head from base:



C0130-00