

INSTALLATION AND MAINTENANCE INSTRUCTIONS

B116LP Plug-in Detector Base

For use with the following smoke detectors:

In US: 1151, 2151
In Canada: 1151A, 2151A
In Europe: 1151E, 2151E



3825 Ohio Avenue, St. Charles, Illinois 60174
1-800-SENSOR2, FAX: 630-377-6495
www.systemsensor.com

156-599-03R

Specifications

Base Diameter: 6.2 inches (157 mm)
Base Height: 0.95 inches (24 mm)
Weight: 0.3 lb. (130 g)
Mounting: 4-inch square box with or without plaster ring. Min. Depth-1.5 inches
4-inch octagon box. Min. Depth-1.5 inches
3-1/2 inch-octagon box. Min. Depth-1.5 inches
50 mm box
60 mm box
70 mm box
Operating Temperature Range: 0° to +49°C (32° to 120°F) US and Canadian Installations
10° to 60°C (14° to 140°F) European Installations

Operating Humidity Range: 10% to 93% Relative Humidity

Electrical Ratings – includes base and detector

System Voltage: 24 VDC
Maximum Ripple Voltage: 4 Volts peak to peak
Start-up Capacitance: 0.02µF Maximum
Standby Ratings: 15 VDC Minimum
35 VDC Maximum
120 µA Maximum
Alarm Ratings: 8 V Minimum at 16 mA
12 V Maximum at 100 mA
(Alarm current MUST be limited to 100 mA maximum by the control panel.)

Relay Contact Ratings:

Resistive or Inductive (60% power factor) Load
Form C:* 2.0A @ 30 VAC/DC
0.6A @ 110 VDC
1.0A @ 125 VAC
Reset Voltage: 1.4 VDC Minimum
Reset Time: 0.3 Seconds Maximum
Start-up Time: 34.0 Seconds Maximum

*For Canadian installations relay contact ratings are 2.0A @ 30 VAC/DC.

Please refer to insert for the Limitations of Fire Alarm Systems

Three-Year Limited Warranty

System Sensor warrants its enclosed smoke detector base to be free from defects in materials and workmanship under normal use and service for a period of three years from date of manufacture. System Sensor makes no other express warranty for this smoke detector base. No agent, representative, dealer, or employee of the Company has the authority to increase or alter the obligations or limitations of this Warranty. The Company's obligation of this Warranty shall be limited to the repair or replacement of any part of the smoke detector base which is found to be defective in materials or workmanship under normal use and service during the three year period commencing with the date of manufacture. After phoning System Sensor's toll free number 800-SENSOR2 (736-7672) for a Return Authorization number, send defective units postage prepaid to: System Sensor, Repair Department, RA # _____, 3825 Ohio Avenue, St.

Charles, IL 60174. Please include a note describing the malfunction and suspected cause of failure. The Company shall not be obligated to repair or replace units which are found to be defective because of damage, unreasonable use, modifications, or alterations occurring after the date of manufacture. In no case shall the Company be liable for any consequential or incidental damages for breach of this or any other Warranty, expressed or implied whatsoever, even if the loss or damage is caused by the Company's negligence or fault. Some states do not allow the exclusion or limitation of incidental or consequential damages, so the above limitation or exclusion may not apply to you. This Warranty gives you specific legal rights, and you may also have other rights which vary from state to state.

Before Installing

Please thoroughly read the System Sensor manual I56-407, *Guide for Proper Use of System Smoke Detectors*, which provides detailed information on detector spacing, placement, zoning, wiring, and special applications. Copies of this manual are available at no charge from System Sensor. (For installation in Canada, please refer to CAN4-S524, Standard for the Installation of Fire Alarm Systems and CEC Part 1, Sec. 32.)

NOTICE: This manual should be left with the owner/user of this equipment.

IMPORTANT: The detector used with this base must be tested and maintained regularly following NFPA 72 requirements. The detector used with this base should be cleaned at least once a year.

General Description

The model B116LP plug-in detector base is used with System Sensor model 1151, 1151A, and 1151E ionization detector heads and model 2151, 2151A, and 2151E photo-electronic detector heads. The capability of plugging these detectors into a variety of special bases makes them more versatile than equivalent direct-wired models. Refer to the System Sensor catalog for other available plug-in detector bases.

The B116LP base is intended for use in 2-wire systems, with screw terminals provided for power and relay contact connections. These bases **MUST** be current limited by the system control panel in the alarm state.

Mounting

This detector base mounts directly to 3-1/2-inch and 4-inch octagon boxes, and 4-inch square boxes (with or without plaster rings). To mount, remove decorative ring by turning it in either direction to unhook the snaps, then separate the ring from the base. Install the base to the box using the screws supplied with the junction box and the appropriate mounting slots in the base. Place decorative ring onto base, then turn in either direction until the ring snaps in place (see Figure 1).

Installation Guidelines

All wiring must be installed in compliance with the National Electrical Code and the local codes having jurisdiction. Proper wire gauges should be used. The conductors used to connect smoke detectors to control panels and accessory devices should be color-coded to prevent wiring mistakes. Improper connections can prevent a system from responding properly in the event of a fire.

For signal wiring (the wiring between inter-connected detectors), it is recommended that the wire be no smaller than 18 gauge. Wire sizes up to 12 gauge may be used with the base. For best system performance, the power (+) and (-) loop wires should be twisted pair and installed in separate grounded conduit to protect the loop from extraneous electrical interference.

Smoke detectors and alarm system control panels have specifications for allowable loop resistance. Consult the control panel manufacturer's specifications for the total loop resistance allowed for the particular model control panel being used before wiring the detector loops.

Locate installations where normal ambient temperatures do not exceed 100°F.

Wiring Instructions

CAUTION

For system supervision — For terminals 2, 3, and 5 do not use looped wire under terminals. Break wire run to provide system supervision of connections.

Wire connections are made by simply stripping insulation from the end of the wire, sliding the bare end of the wire under the clamping plate, and tightening the clamping

Figure 1. Mounting base to box:

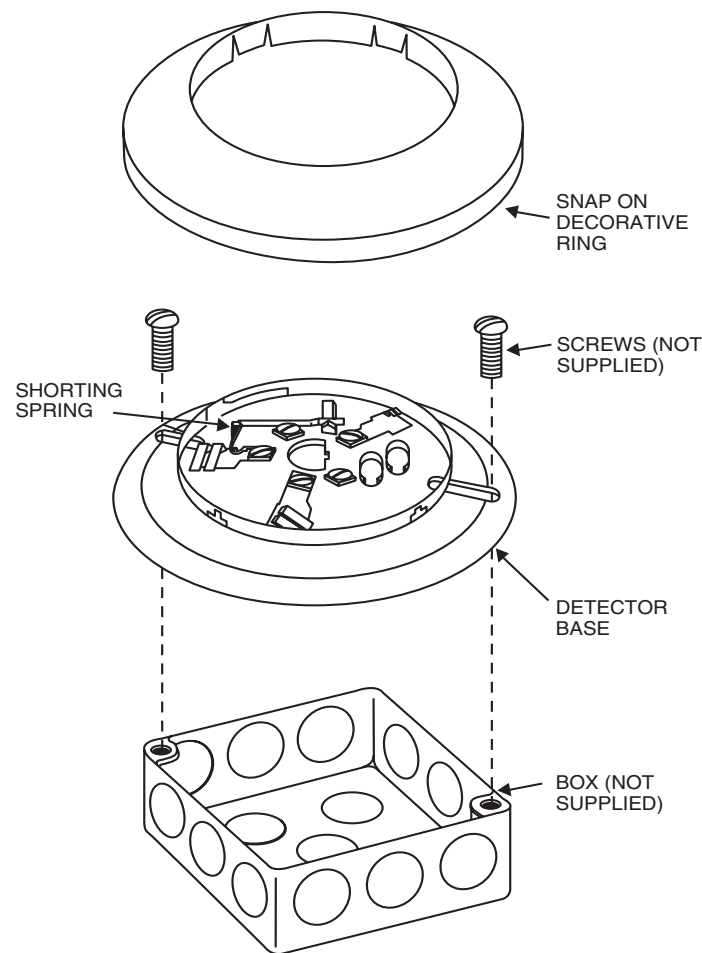

C0503-00

plate screw. Use the strip gauges molded into the inside and underside of the base for ease of wiring to terminals 1 through 5, and to terminals 12 through 14, respectively.

System Sensor smoke detectors and mounting bases are marked with a compatibility identifier located as the last digit of a five digit code stamped on the back of the product. Connect detectors/mounting bases only to compatible control units as indicated in System Sensor's compatibility chart which contains a current list of UL listed control units and detector head/base combinations. A copy of this list is available from System Sensor upon request.

The zone wiring of the detector base should be checked before the detector heads are installed in them. To make this possible, this base contains a special spring-type shorting jumper. After a detector base is properly wired and mounted on an electrical box, make sure that the jumper spring is in contact with the base of Terminal 3. This temporary connection shorts the positive-in and positive-out leads and permits the wiring of the loop to be checked for continuity.

Figure 2. Typical wiring diagram:

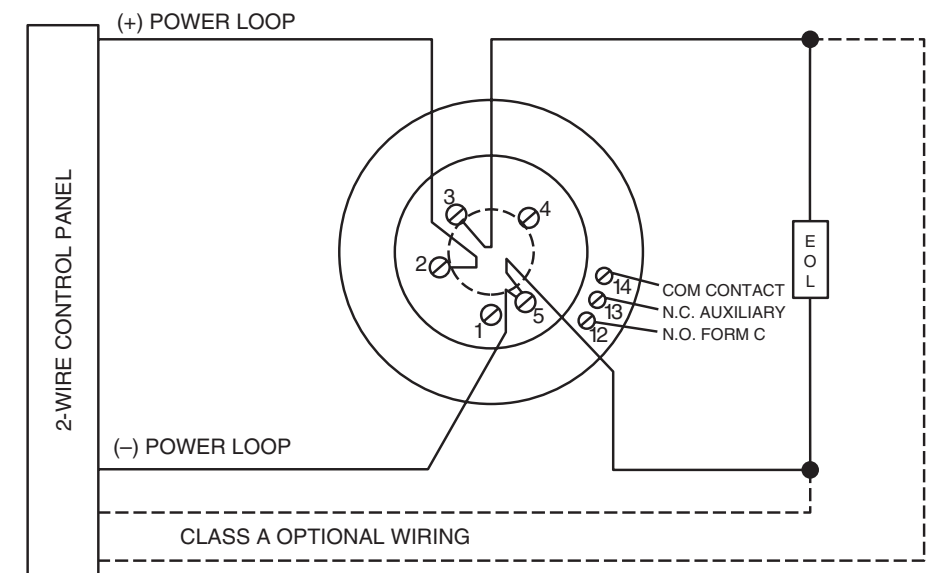

C0566-00

Once all the detector bases have been wired and mounted, and the loop wiring has been checked, the detector heads may be installed in the bases. The shorting spring in the base will disengage automatically when the detector head is removed from the base. **DO NOT** remove the shorting spring since it reengages as the detector head is fully turned into the base, completing the circuit.

Tamper-resistance Feature

CAUTION

Do **NOT** use the tamper-resistance feature if the XR2 Removal Tool will be used.

This detector base includes a tamper-resistance feature that prevents removal of the detector without the use of a tool.

To activate this feature, break off the tab on the detector base shown in Figure 3A, then install the detector. To remove the detector from the base once the tamper-

resistance feature has been activated, place a small-bladed screwdriver into the small hole on the side of the base and push plastic lever away from the detector head (see Figure 3B). This will allow the detector to be rotated counterclockwise for removal.

NOTE: Head removal after the tamper-resistance feature has been activated requires removal of the decorative ring.

The tamper-resistance feature can be defeated by breaking and removing the plastic lever from the base, however this prevents using the feature again.

Figure 3A. Activating tamper-resistance feature:

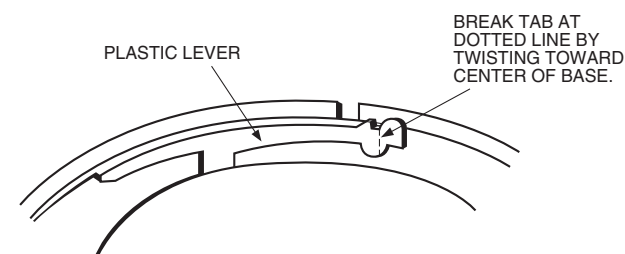
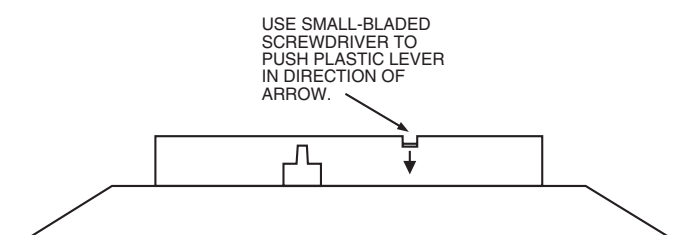

Figure 3B. Removing detector head from base:



C01030-00